



ANTIQUE RADIO CLASSIFIED



Volume 31

Spring 2014

Number 1



Zenith 53 Restoration



Crosley 5-50 Radio



**International Restoration Contest Winner
Atwater Kent Model 708 Cathedral Radio**

**A.R.C. - The International Publication For
Buyers & Sellers Of Old Radios & Related Items**

www.antiqueradio.com



Estes Auctions

Specializing in Vintage Radios
Complete Auction & Appraisal Service

Vintage Radio Auction

Saturday May 17, 2014 - 10AM EST

At the Expo Auction Center
8157 Garman Rd., Burbank Ohio

From I-71 Exit #204 turn south on SR #83 then turn left at the Love's gas station onto Garman Rd., follow it ¼ mile to the auction.

CROSLY WLW SUPER POWER RECEIVER ZENITH STRATOSPHERE 1000Z ZENITH 16-A-63 BABY STRATOSPHERE

Spartan Peach Glass Sled, Spartan Radio Peach Glass Advertising Mirror, EH Scott Console Radios, Trophy Bowling Ball Radio, Crosley Bulls Eye Radio, Lone Ranger Radio, Philco Predicta Television, Beautiful Catalin Radios, Beetle Plastic Radios, NOS Unbuild Heathkits, 1920's Battery Set Radios, Breadboard Radios, Amateur Radio Equipment, a Selection of Microphones, Cone Speakers, Horn Speakers, Rockola Juke Box, Collector Tubes, Advertising Signs, Audio Items, Amps, Speakers, Crystal Sets, Headphones, Magazines, Books, Manuals, Test Equipment, Parts, Edison Standard Phonograph, Edison Home Phonograph, Edison Cylinder Records, Edison Diamond Disc Records, 78 RPM Disc Records, Selection of Console Radios.

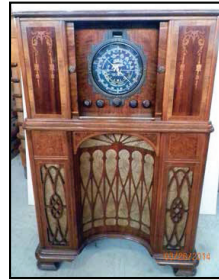
Early Sale 8:30 AM - 10:00 AM
We hope to see you at the sale!



**CROSLY WLW
SUPER POWER RECEIVER**



**ZENITH
STRATOSPHERE 1000Z**



**ZENITH 16-A-63
BABY STRATOSPHERE**

ESTES AUCTIONS

7404 Ryan Road, Medina, Ohio 44256

Ph: 330-769-4992 • Toll Free: 888-769-4992 • Fax: 330-769-4116

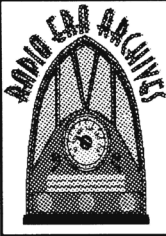
www.estesauctions.com • Email: estesauctions@aol.com

Terms: Cash/Check/Visa/MasterCard: 5% Gallery Fee

Richard Estes, Auctioneer -- Radio Call Sign K8LRY

John Estes, Auctioneer -- Radio Call Sign KB8GEC

Call Us to Sell One Radio or Your Entire Collection! We offer pick-up service for your collection.
auctionzip.com #20507



THE HISTORY OF RADIO ON CD-ROM

Radio Era Archives produced the *QST-VIEW* series of CD's for the American Radio Relay League (ARRL) and over 1/2 million CD's have been sold. *QST* Magazine has been continuously published since 1915. We are now proud to announce that this small mountain of CD's (about 35) is now available exclusively from REA (All Sets) ! Every magazine published from 1915 to 1994, front cover to back cover, every article and column, all accessible with our database search engine.

QST-VIEW CD Edition truly captures the history of radio in 11 volumes. All CD's warranted to work on all Windows platforms from Windows 95 through XP. Each set is \$ 39.95 and we have all sets in stock. The sets are: 1915-1929, 1930-1939, 1940-1949, 1950-1959, 1960-1964, 1965-1969, 1970-1974, 1975-1979, 1980-1984, 1985-1989, 1990-1994. Each set of years is a self-contained set so you can operate one or all sets together. Now that large capacity hard drives are so inexpensive, the 36 CD's can be loaded on about 20Gb of hard disc space for instant searching and viewing without having to swap discs! Full information is provided with each purchase and *QST-VIEW* has on-line instructional help for operating the *QST-VIEW* browser!

EACH SET \$ 39.95 (specify the years)

ALL 11 SETS \$ 379

S&H USA for first set is \$ 5.00, add \$ 1.00 each set thereafter

S&H Export first set is \$ 15.00, add \$ 2.00 for each set thereafter

2009 1/2 PRICE SPECIAL (while supply lasts)

Don't forget, we have the entire John Rider's Perpetual Troubleshooters Manuals on a single DVD. All 23 Volumes of the Riders available at the click of a mouse! Over 120,000 different model radio schematics and related service information in an easy to use DVD. **Thousands sold at \$ 199. SPECIAL \$ 99 + \$ 6.00 S&H in the USA, add \$12 for worldwide delivery. Order Now while supply lasts !**

We now have a small mountain of vacuum tubes at very competitive prices - Thousands sold since our first posting of these tubes. All types including receiving and transmitting types. Tube price listings on the web:
<http://www.radioera.com/tubes.asp>

SCHEMATIC DIAGRAM & MANUAL SERVICE

Over a Million schematics & 100,000 manuals and growing! Schematics and most manuals may be emailed instantly via the internet

Check the web - On-line antique radio flea market - Radios for sale - Antique radio museum - Zenith Trans-Oceanic museum - thousands of old catalogs, manuals, literature, information, how-to data, reference, auction price section and much-much more! Visit antique radios largest web address today!

RADIO ERA ARCHIVES

2043 Empire Central
Dallas, Texas 75235
Inquiries: 214-358-5195

OFFICE HOURS 10AM - 4PM DAILY M-F

Visit us on the Internet:
www.radioera.com

ANTIQUÉ RADIO CLASSIFIED

Spring 2014 • Volume 31 • Number 1

The International Publication for Buyers and Sellers of
Old Radios and Related Items – Published Monthly

www.antiqueradio.com

-
- | | |
|---|--|
| <p>3 Publisher's Comments</p> <p>4 Zenith 53 Restoration
by Charles A. Days</p> <p>7 Heathkit AJ-11 Tuner
By John Vuolo</p> <p>11 Cleaning Noisy Potentiometers
January 2014
Daniel Schoo</p> <p>16 At Home with the Collector
By Staff</p> <p>19 Book Review – The Early Short
Wave Stations
By Jerome S. Berg, Reviewed by Bart
Lee</p> <p>21 Repairing an Early Utah Drum
Speaker
By Daniel Schoo</p> <p>26 The Crosley 5-50
By Dave Crocker</p> | <p>28 Major Shootout of Best Perform-
ing 1930's High-End Radios
By Richard Majestic</p> <p>31 The New England Antique Radio
Club Radio XLV Meet</p> <p>34 The DuKane Ionovac Speaker
By Daniel Schoo</p> <p>41 An e-Embarrassment of Riches
By Dave Sica</p> <p>42 A.R.C Announces Results of the
First International Restoration
Contest</p> <p>44 Photo Review</p> <p>48 Classified Advertisements</p> <p>53 Coming Radio Events</p> <p>57 Radio Clubs</p> |
|---|--|
-

Antique Radio Classified (ISSN:8750-7471) is published monthly on the Internet and 4 times a year in Printed Form, by Vintage Radio Publishing, LLC, PO Box 1558, Port Washington, NY 11050. Periodicals postage paid at Port Washington, NY, and additional mailing offices.

Annual subscription rates: U.S. - \$36.00 by Periodicals mail, \$48.00 by First Class mail; Canada - \$50.00; Mexico - \$60.00; other foreign countries - \$70.00. Web-Only - \$30.00. For multiple year rates see website.

© 2014 by Vintage Radio Publishing, LLC

POSTMASTER: Send address changes to

Antique Radio Classified, PO Box 1558,
Port Washington, NY 11050.

Printed in U.S.A.

PURPOSE - *Antique Radio Classified* is published for people involved in the radio collecting hobby. Its purpose is to stimulate growth of the hobby through the buying, selling and trading of radios and related items, and to provide a monthly forum for the interchange of ideas and information.

Publisher: Jon Kummer; **Layout:** Maureen Schwarz; **Publisher/Editor Emeritus:** John Terrey; **Founding Publisher/Editor:** Gary B. Schneider; **Contributing Editor:** John Terrey; **Contributing Writers & Consultants:** Mike Adams, Ray Bintliff, Dave Crocker, Daniel Schoo, John Vuolo, Richard Majestic.

CONTACTING ANTIQUÉ RADIO CLASSIFIED

All correspondence should be sent to:
A.R.C., PO Box 1558, Port Washington, NY 11050
Telephone: (866) 371-0512; Fax: (516) 883-1077
Email: ARC@antiqueradio.com
Web: www.antiqueradio.com

Unfortunately, A.R.C. is not staffed to answer all letters with questions about antique radios or requests for advice. However A.R.C. does solicit letters of interest from its readers and publishes them as space permits.

ADVERTISING. Display and Classified advertising rates and artwork specifications are available on the web site.

CHANGE OF ADDRESS. Please notify us in advance of a change of address. Send your new address, your old address, your SUB# and the effective date of the change.

PUBLISHING RIGHTS. Unless other arrangements are made: (1) All received materials (ads, articles, letters, correspondence, email, photos, artwork, etc.) become the property of A.R.C., may be edited, combined with other material, published, and will not be returned. (2) For all received materials, A.R.C. is granted publishing and reprint rights in all forms of media including the monthly printed magazine, internet, etc. (3) Publication is subject to approval by A.R.C. and to time and space constraints.

DISCLAIMER. The publisher is not responsible for any buying and selling transactions incurred, or for any other use of the contents of this publication.

NOTICE. Subscription rates, frequency of publication, content, policies, size and ad details, and rates are subject to change at any time by A.R.C.

ATTENTION SUBSCRIBERS: All paid subscribers receive a **FREE** classified ad of up to 50 words in each issue.



Publisher's Comments

CHANGE IS GOOD

This is the first issue of Antique Radio Classified to be printed since the March/April 2013 issue but we started to publish A.R.C. on our web site in February 2014.

The antique radio community as well as the magazine publishing market is changing and we are changing what we do and how we do it in order to continue providing the number one magazine in the world for collectors of antique and vintage radios and electronic equipment.

Effective with the February 2014 issue, A.R.C. will continue to be published every month on our web site www.antiqueradio.com. Each issue will still have 52 pages as we have had for the previous 3 years. However, the print version of the magazine will become a quarterly publication. Every 3 months, the previous 3 issues will be combined into a single print edition.

You are holding the Spring 2014 issue which is our first quarterly issue and contains all the articles from the February, March, and April 2014 magazine. It also contains the Photo Review section, Coming Events for the next 3 months, Radio Club list, and the latest Classified ads.

Yes, there is an economic component at play here. The cost to print and mail the magazine has risen over the years but the revenue from subscribers and advertisers has not and therefore we must find a compromise. A monthly web edition becomes more sensible since the number of subscribers with computer access is well in the majority. Also, much of the inter-collector activity has shifted to the web. A.R.C. must embrace this reality to continue to serve the collecting community.

All subscribers will receive the number of monthly print issues that they subscribed to – future issues arriving monthly via the web, and three at a time by mail. Your mailing label has been changed to indicate your extended expiration date.

If you would like to view the web version

of A.R.C. but haven't had the chance or don't know how to log on, give us a call. We will show you how easy it is. If you don't own a computer most public libraries have a computer available for the public and there is an excellent chance that a family member or friend will let you use their computer.

I know this is a compromise but these positive changes will enable A.R.C. to continue to serve the antique and vintage radio and electronic equipment collector into the future.

THE FUTURE

We need you to be part of the future. Antique Radio Classified needs your input to make it successful. Our biggest challenge has always been the ability to have people write articles, send in pictures for the Photo Review, and to keep us updated on radio meets and radio club contacts.

An article can be as simple as writing 2 pages and taking 5 photographs. A Photo Review submission is simply a photograph and 2 sentences. You don't have to be a great writer – we will edit the article for you. An article can be the details about a radio meet, restoration of a piece of equipment, technical theory, how you found a rare radio, or even how you found that radio you listened to with your grandfather! You can write about radios, televisions, test equipment, audio equipment, and much more. Give us a call and let us know if you have an idea for an article that you would like to see.

Thank you for your support and I look forward to meeting you at a future radio meet.

Happy collecting!

Jon Kummer
Publisher

On The Cover

The cover of our first quarterly issue shows the covers of the February, March, and April 2014 issues.

Zenith 53 Restoration

BY CHARLES A. DAYS

Part 1



I was contacted by a friend that a Zenith radio was for sale at a home near a local public park. This area is lined with many homes built in the Craftsman style. See the image to the right. We both met at the home and were escorted to the central staircase by the owner to an unfinished 2nd floor. Near the center of the large room was the Zenith in immaculate physical condition. Seeing the light of day through the dial opening I asked where's the chassis? "We don't know" was the reply from the owner. So the negotiation was quick, \$15, my friend helped me load it for the quick trip home.



was attached. Careful wiping with solvent on the label revealed it was for a 53. I did not have a computer at the time, 1996, so hope for finding a chassis was in the form of a want-ad placed in Antique Radio Classified.

I had very little information about the Zenith, in fact I wasn't even sure of the model until I found the label which had been sealed securely to the speaker shelf nearly as dark as the wood it

The ad produced several replies, knowing that one chassis would probably have issues,



I opted for two chassis, power transformers, two different styles of the Zenith "Automatic" mechanical push-button tuners and one speaker.

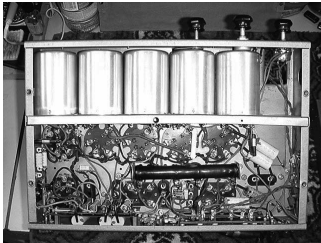
Fast forward to 2012, time to get the Zenith 53 together. Both chassis proved to have serious issues with each, but there were sufficient parts in both to create one. My choice of the "good" chassis was not without cosmetic issues, one chassis had been repaired in the past with a "stuffed" electrolytic condenser. The technician had taken a chisel to the chassis to open a huge hole to clear the condenser studs, that chassis was not suitable. The other chassis, appeared to have been operated for some time out of its cabinet in an area where spray painting had taken place. Apparently, lacquer was spilled over the top, sealing in accumulated dust, flowing over the sockets and speaker connections. A quick check with solvent proved it was possible to remove the mess but the original OEM dull gold paint would go away too. All the hardware that wasn't riveted was removed, the wiring bundled and the chassis carefully stripped revealing nickel plated steel in good condition.



All the tube sockets and wiring were masked off, the chassis and condenser housing got two quick coats of gold hammer-tone. I chose the hammer-tone finish not only for

the hiding power but also gold paint is difficult to apply uniformly. The transformers, filter condenser housing and the tube shields were done in a bronze hammer-tone. The image shows the chassis just prior to masking. I used an easy release masking tape leftover from a home renovation project.

The tuning condenser on the chosen chassis had serious pot-metal issues on two of the stators. The tuner of the donor chassis had the same problem so two stators were exchanged. The repaired tuning condenser was thoroughly cleaned and lubricated. The stators were all re-aligned and the rotor manipulated countless times to insure good contact. The coil assembly was also transferred from the donor to ensure the radio would track.



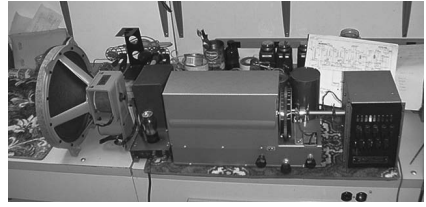
Some of the paper OEM bypass condensers were in multiple blocks,

others as singles, all of which were in potted tin housings.

This would have been a nightmare to re-fit as well as the filter condenser. So the blocks were removed with anticipation that feedback could occur. They were all replaced by individual capacitors in strategic locations. These separate condensers actually reduced the under-chassis clutter. The same was done to the filter electrolytic as individual capacitors under the chassis. The newly painted OEM housing was assembled with an empty cleaned vegetable can enclosed to keep the half-shells intact.

The chassis had to have a modification to support the pilot lamp connector for the Zenith "Automatic" tuner. An opening for the socket was already punched. A socket was carefully removed from the donor chassis and was wired to the filament circuit. The donor also provided the tapped power resistor and the second audio driver transformer

The chassis was completed electrically and



connected to one of the ZE-50 power transformers, Zenith anticipated variations in line voltage and the 125 volt tap was selected with the jumper fuse. Powering the radio was uneventful, however, badly out of alignment, re-alignment was more than the process of simply adjusting the mica trimmers on the tuning condenser. The five section tuner has four sections that have copper outside plates, these are relatively soft and easily bent. Through a process, repeated several times, the tuning system was brought into tracking by careful bending of the copper plates. The chassis became more sensitive each time the adjustments were repeated. The Zenith 53 as well as several other models in this series does not have automatic volume control circuitry. This took a toll on the OEM volume control and the speaker surround during the alignment process

This image is the rear view of the completed chassis, note the speaker to the left in



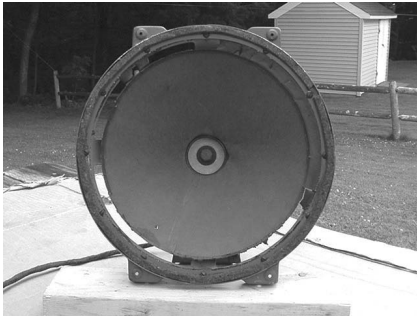
its final re-furbished iteration with a foam surround exponential cone and felt buffer gasket.

The volume control in each of the chassis was configured differently, one had a two section control which changed both the antenna input and the screen bias of the RF amplifier tubes. The other volume control system consisted of changing the screen bias of the RF amplifier tubes only. The dual control began to fail and developed a flat spot. I opted to changeover to the single control but that too was well worn. The entire control was re-

Attention Subscribers: You can access a color version of this article on the A.R.C. website at www.antiqueradio.com.

placed using a single control found in stock, it was a linear and proved to be a better choice for voltage control and yielded smooth volume without an abrupt change. The new volume control had to have the shaft not only cut to length but cross drilled to accept the knob retaining spring.

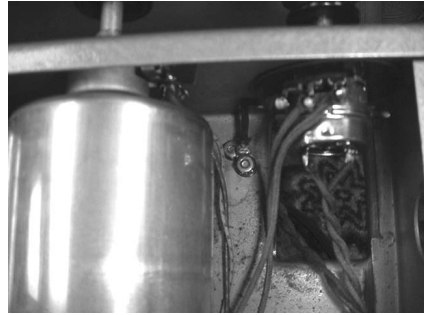
The antenna input circuit having removed the volume control, was also modified by the addition of a mica capacitor across the antenna trimmer, a help to tune shorter antennas.



The Farrand speaker, as shown above, was in poor condition having been exposed to some of the spilled lacquer, splatters of blue auto paint and general deterioration of the hardened leather surround. The process of alignment with the blasting of the audio not only broke up the surround but also began to shatter the cone that had decomposed as well.

As the radio tuning and speaker were so much improved it became evident that the the fidelity was exceptional to the point of distraction. The AM receiving environment in my area is somewhat plagued with electrical noise. I felt that to at least abate the noise some sort of treble cut was necessary. To accomplish this, looking forward to later models of Zenith chassis schematics, I found that some models did indeed have a treble control. So an experimental value of capacitor and rheostat were chosen and clipped in. A couple of different values were tried, a capacitor and rheostat combination that when the maximum of resistance was dialed there was only the slightest perceptible loss of high frequencies. When the resistance was minimum male voices were still clear. The effect was both the absence of static and a mellow tone. Again, a new rheostat was found for the purpose, linear as well, as this seemed to yield the best adjust-

ment range. A knob was found on-line and a wire retainer fabricated from a spring.



The new tone control position had to be found on the chassis to both look pleasing and to clear the RF coil shield cans beneath the chassis. The dimensions were translated to the cabinet and carefully bored from both sides to prevent chip out of the veneer. As seen in the image on the right, the chassis provides only the minimum amount of clearance for a tone control. The coil assembly had to be removed for the installation of the new tone control as seen on the upper left of the image at the right.

In Part 2

I will cover in detail, the refurbishing process of the Farrand speaker. The retrofitting of the Zenith "Automatic" mechanical push-button tuner with station memory indicator. The replacing of the asphalt wire looms and the fabrication of a replacement back with an additional lower back to keep out the household pets. A list of all materials and vendors will be provided.

Charles A. Days is a retired consulting electronic/electromechanical technician, an Amateur Radio operator WA1JFD and has been collecting radios since 1957. He lives with his wife in S. Dartmouth, MA. pacquer-at@comcast.net or 508-984-5599, member of the ARRL the AWA and NEARC.

Heathkit AJ-11 Tuner

BY JOHN VUOLO

Introduction

The Heathkit Model AJ-11 Tuner is two independent tuners; an AM (amplitude modulation) and an FM (frequency modulation) contained onto one single chassis. Heathkit touted high quality construction, versatility, excellent performance and attractive styling of the AJ-11's design. See photos of AJ-11.

Heathkit utilized a prebuilt pre-aligned FM front end in an all steel vinyl clad cabinet, and the heavy die-cast flywheels which provide positive action of the individual AM and FM tuning controls. The separate tuning indicator eye tubes simultaneously monitor AM and FM tuning. This feature is very desirable when receiving FM and AM broadcasts. Adjustable automatic frequency control and a limiter-ratio detector combination provide stable broad band FM reception. The AM section contains a built-in rod type antenna with provision for connecting an external antenna if needed.

A pre-aligned and preassembled FM front end is supplied for ease of construction, and to provide for consistently good FM performance. The full-wave, voltage-doubler power supply uses silicon rectifiers which reduce heat and provide excellent voltage regulation.

Circuit Description

AM Tuner

AM (amplitude modulation) refers to a constant frequency RF signal (carrier) whose amplitude is varied (modulated) by the audio being transmitted. See figure 1.

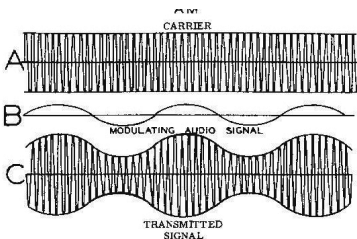


Figure 1

The modulated RF signal is received by the tuner's AM antenna and is applied to the grid of the RF amplifier tube V1 (6BA6). The amplified signal from V1 is then coupled to the grid of the mixer-oscillator tube V2 (6BE6). The AM oscillator is then tuned to a frequency of 455 kilohertz higher than that of the RF signal being received at the grid of V2. As a result, both the oscillator and RF signals are present at the grid of V2, along with the sum and difference of these two signals. These signals contain the same modulation as the received RF carrier, are applied to T2, the first IF transformer. Transformer T2 is designed to accept only the difference of 455 kilohertz. The electrical makeup of the transformer contributes to the excellent fidelity of the AJ-11. It has a special winding to control the amount of inductive coupling between the primary and secondary circuits. When the AM fidelity switch is placed in the MAX. position, Transformer T2 is over-coupled, and a response curve as shown in figure 2A results. In the NORMAL position, the coupling is decreased, and the resulting response curve is shown in figure 2B. The signal from the secondary winding of T2 is applied to the grid of the IF amplifier V3 (6BA6).

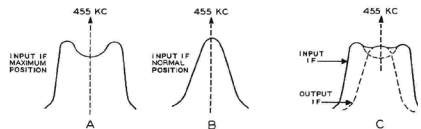


Figure 2

The diodes of V4A (6BN8) are connected to provide a negative DC voltage and an audio signal across R11 (150 K ohm), the diode load. The negative DC voltage is applied to the grid of each tube in the previous stages to control their gain. Strong stations provide more negative DC voltage which reduces the gain of the previous stages. This action is called AVC (automatic volume control). Negative DC voltage from V4A (6BN8) is also applied to the control grid of the tuning

indicator eye tube V10 (6M-E5) which indicates received signal strength and proper tuning by the amount of eye closure. Coupling capacitor C22 (.02uf) allows the audio signal from V4A to pass to the grid of the cathode follower V4B (6BN8). This stage provides isolation between the output jack and the detector stage, preventing loading of the detector. The audio signal is then coupled from the AM LEVEL control, in the cathode circuit of V4B, through the MODE SELECTOR switch to the output sockets. A whistle filter in the cathode circuit of V4B is used to reject the 10 kilohertz beat signal that often occurs between two adjacent stations when received on a wide band AM tuner.

FM Tuner

FM (frequency modulation) means that the carrier amplitude is held constant while the carrier frequency is varied above and below the station frequency at a rate determined by the audio being transmitted. This can be seen in figure 3. The audio signal (B) is applied to

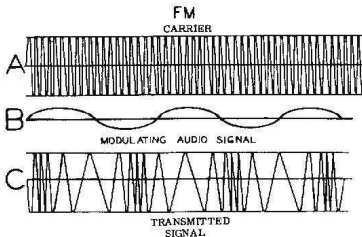


Figure 3

the RF carrier (A) to produce the FM signal (C). This signal is received by the FM tuner antenna and is applied through a bandpass filter, consisting of coil L5 and C29A to the grid of RF amplifier tube V5A (6C9). The amplified signal from V5A is coupled through C33 (1.5pf) and the secondary of L7 to the grid of the mixer oscillator tube V5B (6C9). The local oscillator tank circuit made up of C29E and the primary coil of L7 is tuned to operate the 10.7 megahertz above the received FM signal. The oscillator signal and the received signal are mixed in V5B. The output of the tube then contains three frequencies; the received FM signal frequency, the sum of the oscillator and the signal frequencies and the difference of the oscillator and signal frequencies. These signals are then applied to the first IF transformer T5, which passes only

the difference frequency of 10.7 megahertz. Then the 10.7 megahertz signal from T5 is applied to IF amplifier tube V6 (6AU6) and is then coupled through transformer T6 to the second amplifier tube V7 (6AU6). From V7 the amplified 10.7 megahertz signal is applied through transformer T7 to limiter stage V8 (6AU6).

The amount of signal at the grid of V8 determines the value of negative DC voltage developed at this point. The negative DC voltage is applied to the grid of eye tube V11 (6M-E5) which indicates signal strength and proper tuning. V8 acts as an IF amplifier for weak signals and as a limiter for strong signals. The limiter stage in the FM tuner is used to remove any amplitude modulation of the FM signal. See fig 4. The limited signal from V8 is ap-

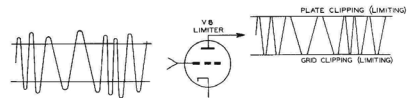


Figure 4

plied through transformer T8, to ratio detector tube V9A (6BN8). The ratio detector does the same job in an FM tuner as it does in an AM tuner. It recovers audio from the modulated IF signal. If the oscillator frequency changes (drifts), a small negative DC voltage is developed in the ratio detector. This voltage is applied back to the grid of the oscillator tube to correct the frequency drift. The audio signal from the ratio detector is coupled through the MODE SELECTOR switch to the output sockets.

Power Supply

The power supply uses a full wave voltage doubler circuit consisting of D1, D2 (1N4003), and capacitors C67 and C68 (40, 40uf@150VDC). Capacitors C69A, C69B and C69C (80, 40, 20uf @150VDC) with resistors R46 and R47 (220, 330 ohms 2W) make up the filter network to remove ripple from the DC voltage.

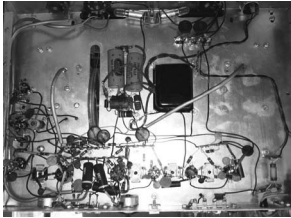
Common Types of Repairs

These tuners usually show up either on EBAY or at garage sales or swap meets. I personally own one of these tuners and I have had the opportunity to repair several others for friends. The following types of repairs are

what I did to get them going again. I normally do most of this before I attempt to power the unit up. I have also provided the Heathkit Schematic of the AJ-11 for reference.

Power Supply – Replace all the electrolytic capacitors, resistors and the silicon diodes in the power supply. I also upped the wattage of the 2 resistors in the power supply from 2 to 5 watts. I then scoped the DC output to insure that the DC is as clean as possible. As these units were made in the early 1960's it just makes sense.

Tube Testing -- Next would be to pull all the tubes and test them to see if there are any that are weak or shorted.



Chassis -- After that I would use a cleaner degreaser on the underside of the chassis to remove the dust and dirt buildup of over 50 years. I then would check for any loose or cracked wiring and repair that. Also look for any cold solder or too much solder on the point to point wiring.

Components -- Next is to measure all the resistors to see if any have gone up in value and replace those. If there are any electrolytic or tubular capacitors definitely replace those. It is also a good idea to check the variable capacitors and make sure they turn freely and do not bind. Make sure the tuning plates are not touching. I have also seen the tuning flywheels bind up on these tuners so a careful cleaning and lubrication may be needed. If you need to restring the tuners to the dial it is recommended that you have the service manual. It is also recommended that you clean the rotary switches and potentiometer using a good cleaner / degreaser.

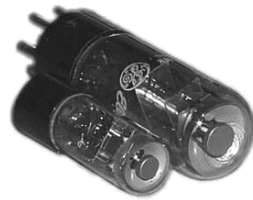
Start Up -- At this point I was ready to power up the tuner. Even though I went through the set I always use a variac and bring the voltage up slowly. I then performed the alignment on the AM and FM tuners. You need a signal generator, scope and a meter to do this correctly. I did run across some of the ceramic disc capacitors that Heathkit used had changed in value and had to be replaced. In the re-alignment process you may need to touch up

the IF (intermediate frequency) transformers to achieve maximum results especially if you replace the capacitors in the IF circuit. I have this tuner connected to my EICO ST40 and it works well.

6M-E5 Eye Tube



Heathkit decided to use the now scarce 6M-E5 tube in their AJ-11 tuner. This tube is a smaller version of the more popular 6E5 tube. The 6M-E5 uses a smaller 7 pin base and its heater current is 150 milliamps versus the 6E5 300 milliamp current. The 6M-E5 can be tested on a TV-7 using the following settings. For an emission and pattern open measurement set the TV7 to 6.3V and the selector switches to ET0-5070, bias 0, shunt 0, range A and push 4. To measure for gm set the TV7 to 6.3V and the selector switches to ET1-2070, bias 17, shunt 0, range B and push 3. To measure the pattern closure set the TV7 to 6.3V and the selector switches to ET-1 5270, bias 0, shunt 100, range A and push 3. You will also need a 7 pin miniature tall test socket adapter to fit the TV7 miniature test socket. A recent check on EBAY shows these tubes being sold for \$39.00 so they still come up from time to time. The 6M-E5 tubes I saw are



EICO labeled so they were also used in some of their products. A photo of the 6M-E5 and a 6E-M5 next to a 6E5 shows the size difference.

Observations

The Heathkit AJ-11 is a simple tuner performs well with an adequate antenna. The AM portion of the tuner has only one IF stage so weak stations will be hard to pull in unless you add the external antenna. The FM portion of the tuner has two stages of IF and with an adequate antenna the weaker, distant stations can be picked up. The unit is reliable

and does need to have ventilation especially when placed into an audio cabinet or enclosed wall unit with a tube amplifier. Excessive heat will affect its operation. Heathkit and other manufacturers at the time provided the ability to connect an external MPX (multiplexer) unit to achieve FM stereo. This was done because the FCC had not yet settled on a FM stereo MPX design and radio manufacturers weren't going to speculate on which MPX design was going to be adopted so they provided an FM output to allow for the final FM MPX design to use. Heathkit as well as several other radio manufacturers provided separate external MPX adapters so you did not need to use the Heathkit MPX adapter with the AJ-11.



References

- Heathkit AJ-11 Assembly Manual
- RCA Receiving Tube Manual



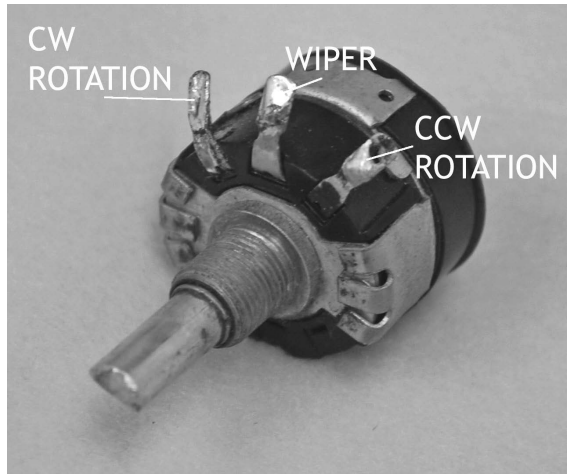
Cleaning Noisy Potentiometers

JANUARY 2014

DANIEL SCHOO

What exactly is a “potentiometer”? A potentiometer is a resistive voltage divider that has the capability of being adjusted to any desired ratio from 100% to zero. Inside there is a resistance element that has a sliding electrical connection or tap that slides from one end of the resistance element to the other. In this way the ratio of the resistance from the tap to either end of the element can be changed thereby changing the voltage division ratio. Potentiometers are manufactured in many different resistances, “tapers” and the number of turns the shaft will make depending on the application they are intended for. For precision work potentiometers allowing five, ten, fifteen or more turns are used to spread out the change in resistance over a longer range of shaft travel and allow more precise setting of the value. Single turn types are the most common having a rotational limit of 270 degrees.

The construction of single turn potentiometers tends to be very similar. Most of the newer ones use a flat ring shaped element with the rotor parallel to the element. Some older ones use a cylindrical shaped element with the wiper sliding inside as shown in the photos. There are always the oddballs you will run into especially in the very old sets. One pot I took apart did not use a sliding wiper at all. It had a flexible metal strip mounted inside of a cylindrical sleeve element. The rotor had a point on it that pressed on the strip deflecting it and pressing it against the element. As the rotor was turned it pressed the strip onto the element at one location similar to how a wiper would contact the element. There were no sliding electrical contacts in the pot. I suppose there could be advantages to this since

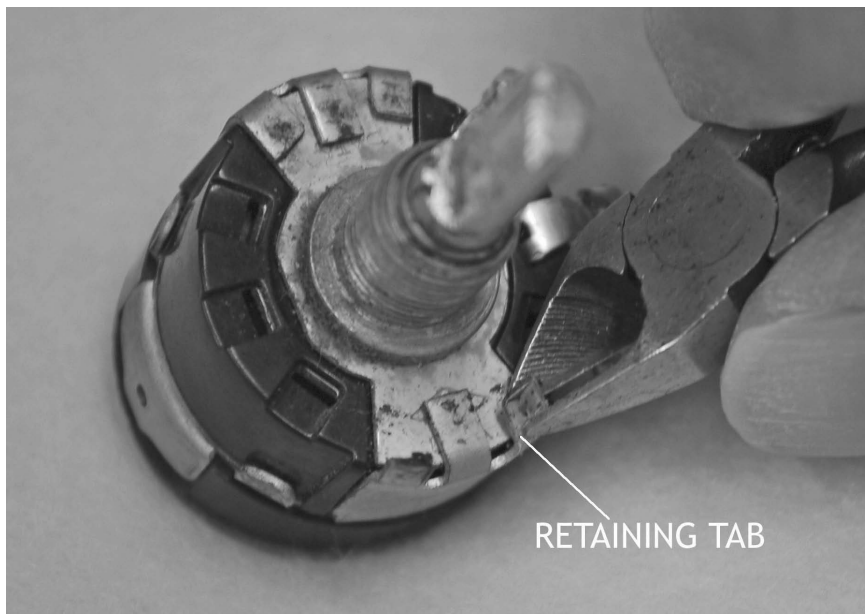


A typical All American Five volume control.

there was no wear on the resistance element but there was also no self-cleaning of the element due to friction.

The taper of the potentiometer refers to the rate of change of resistance as the shaft is turned. A linear taper changes resistance in equal increments as the shaft is turned. For example, setting the shaft at the mechanical half way point of the rotation adjusts the resistance at the tap to exactly half of the total resistance of the element. This taper is used for setting reference voltages such as set points for temperature control, adjustable power supplies and most other applications where a linear change is desired.

Since the human ear is a logarithmic sensor where the perceived volume of a sound is the log of the sound pressure level, the change in resistance of a linear potentiometer does not match the change in perceived volume. A linear potentiometer used as a volume control will advance the perceived volume very slowly as the shaft is turned and then increase rapidly as you reach the end of rotation. To match the human ear the change in resistance,



Bending the retaining tabs for back cover removal.

or taper, must also follow a logarithmic curve changing very rapidly at first and then more slowly as you turn the shaft.

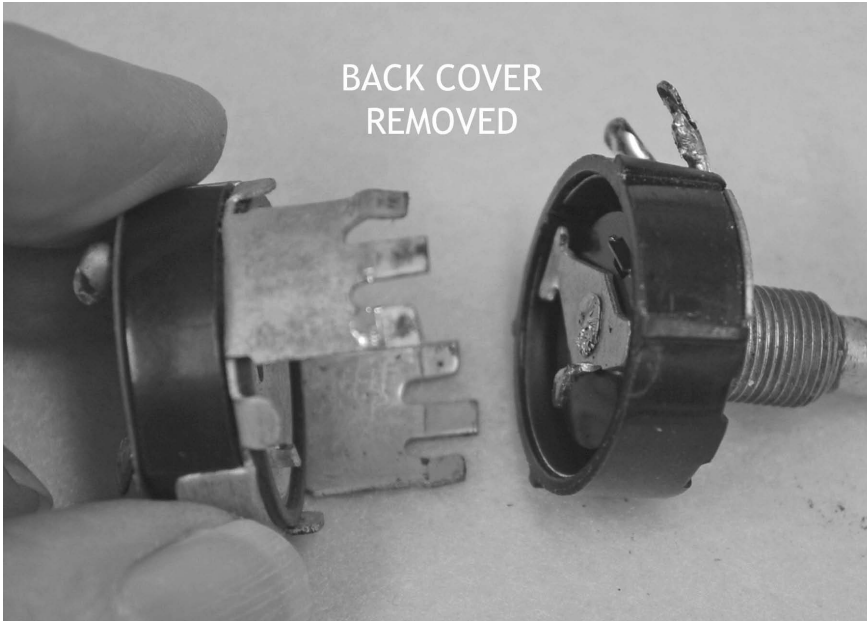
This is one way you can determine if a pot from your junk box is linear or log taper. Set the rotation of the pot to the half-way point between the limits and measure the resistance from the center wiper connection to each of the two ends. If it is a linear pot the resistances should be about equal and half the total resistance. If the resistance from the wiper to one end of the element is very low and to the other end is much higher the pot is a log, AKA audio taper. For this article we will describe the typical single gang volume control used in tube type radios. Dual ganged types used in stereo systems are similar but can be more difficult or impossible to disassemble the front section.

It is very common for potentiometers used as volume controls, tone controls and other audio functions to get dirty and noisy with age and exposure to dust and airborne contaminants. The symptoms are all too common, scratchy noises when you rotate the shaft, intermittent cutout of the audio and noisy audio. Many potentiometers are lubricated at the factory with grease on the shaft and internally on the sliding contacts. After many years of service or storage the grease becomes gummy

and stiff making the shaft difficult, or sometimes impossible, to turn and the electrical conductivity of the sliding contacts poor. The only solution is to remove the grease and get those contacts clean again.

Years ago in the heyday of tube electronics several commercially available cleaners such as Quietrol and No Noise were sold to clean and lubricate dirty switch contacts and noisy pots. Many of them were based on carbon tetrachloride, AKA Tetrachloromethane, a very good solvent for grease. It was non-flammable and relatively non-toxic but its use was discontinued for non-industrial use due to several health and environmental issues. Freon TF is an excellent grease solvent used for electrical contact and magnetic recording head cleaning but it was removed from the market due to environmental concerns. There are several products on the market today for contact cleaning based on flammable alcohols or hydrocarbons and the more expensive non-flammables such as Hydrochlorofluorocarbon (HCFC) solvents.

To properly clean a potentiometer you have to effectively remove all the grease. If the problem is not too bad you can often flood the pot with the solvent and rotate the shaft repeatedly from stop to stop to scrub the con-



Back cover removed.

tacts and resistance element. This will sometimes work for a while and then the pot gets noisy again. Another irrigation or disassembly and cleaning may be necessary for those.

Irrigating the inside of the pot is possible with some types that have openings in the case near the solder lug connections. Other pots are fully enclosed and getting solvents inside in sufficient quantities is not possible. For those and for pots that have a stiff or frozen shaft you have to take the pot apart for a more thorough cleaning.

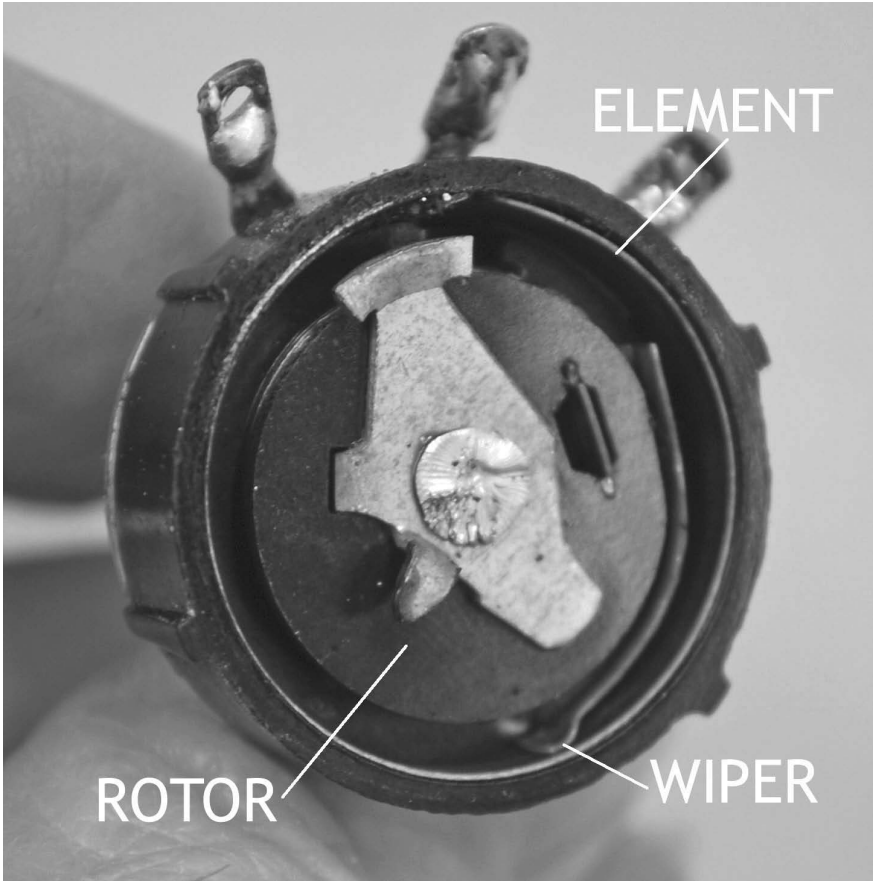
To open a pot for cleaning you must first remove it from the chassis. This can be very difficult depending on how deeply it is buried. This is why the irrigation method of cleaning is so popular. If there is a switch attached to the back, rotate the pot to turn on the switch before disassembly. This will become important when you reassemble the back cover. There are several retaining tabs on the front that hold the back cover to the sleeve. To remove the cover, slip the jaw of a small wire cutter under each tab and gently bend them upward. After all the tabs are straightened the back should slip off exposing the inner workings. The shaft and rotor are removable on most pots but not all.

To remove the shaft and rotor you first re-

move the back cover as described above. Note that there is a retaining ring on the shaft where it enters the threaded portion of the sleeve. Clamp the shaft in a vice and using two small screwdrivers remove the ring. The ring is going to rotate around the shaft so hold it with one screwdriver while using the second driver to push it open and off of the shaft at the split in the ring.

Once removed, the shaft and rotor will slide out of the sleeve. Dried out grease may make this difficult. Applying a little solvent and gently rotating and/or tapping on the end of the shaft may help. You can use one of the commercially available contact cleaning chemicals or a mild solvent such as ethyl or isopropyl alcohol. Never use gasoline, turpentine, methyl ethyl ketone or other industrial or household cleaning products that could damage the resistance element.

Clean the resistance element with a cotton swab dipped in solvent. Often there is thick gummy grease on the element and on the stationary wiper contact ring inside the pot. Carefully swab all of the parts with solvent including the shaft and inside the sleeve. If the wiper contacts are badly tarnished I use a little Brasso on a cotton swab to burnish them. After burnishing, clean them with solvent to



Inside of the pot showing the rotor and sliding wiper.

remove any residual polish. I don't usually put any lubricant on the resistance element or the wiper but I do put a thin film of light oil on the shaft before re-assembly. If your solvent is a commercially available contact cleaner/lubricant you will already have lubricated the contacts.

If the design is such that the rotor is not removable you can clean the contacts with a paper towel moistened with an appropriate solvent. Flood the pot with solvent and rotate the shaft to clean the wiper slider and dissolve the grease out of the inner parts. This is not as good as taking the rotor out but if the pot cannot be disassembled this is the best you

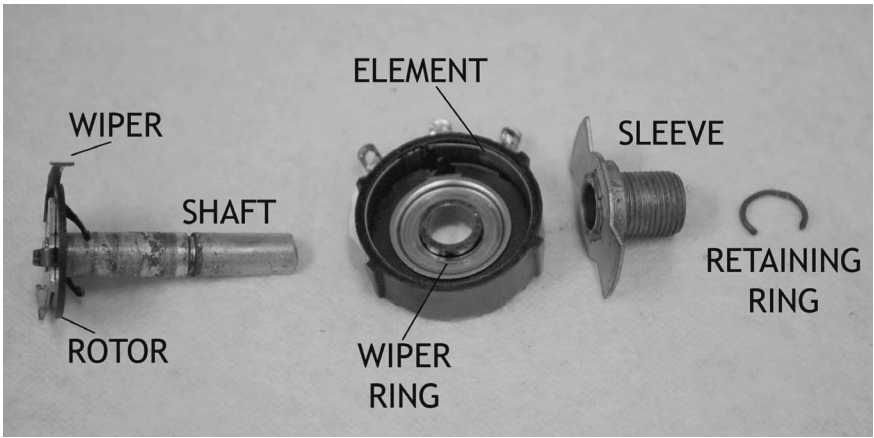
can do. Slip a small piece of dry paper towel gently under the wiper contacts. Once in place moisten it with a small amount of solvent and rotate the shaft slowly to slide the towel over the length of the resistance element. Do this a few times adding additional solvent then remove the towel. Never use an abrasive like sandpaper to clean the internal parts of a potentiometer. Sometimes a little burnishing of the shaft with a light duty Scotch-Brite™ abrasive pad is appropriate to clean up corrosion and hardened grease.

Re-assemble the pot in reverse order. Rotate the shaft to place the main wiper at mid rotation which is farthest away from the solder

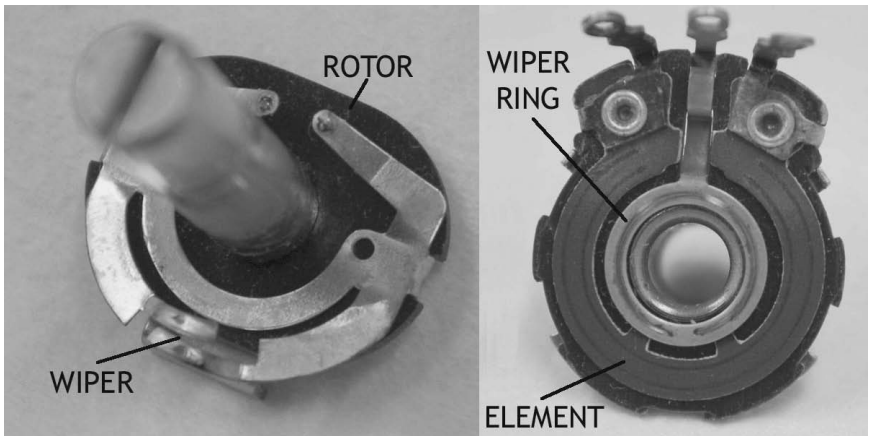
lugs. Put the retaining ring back into the slot in the shaft and squeeze it tight with long nose pliers. To bend the tabs back into place you will need narrow pliers with a very wide opening of the jaws. I use six inch long nose Vise Grip® pliers which have a very wide opening and the jaws are relatively parallel to each other even when widely separated. Gently

squeeze the tabs with the pliers and push them forward towards the shaft to get them started. Carefully flatten the tabs back down and re-install the pot.

You may want to practice disassembly on several junk box pots to get some experience before you try it on a treasured collectable.



Component parts of the potentiometer.



Rotor with wiper contacts on the left, resistance element and wiper ring on the right for a flat disk type potentiometer.

AT HOME WITH THE COLLECTOR

Pat – The Television Collector

BY STAFF

I had a chance to visit with Pat, a well know collector of antique and vintage televisions who is based on the east coast.

Pat probably has over 100 televisions in his extensive collection covering the 1940s, 1950s, and 1960s.

He not only collects televisions but is also an expert at repair and restoration with many spare parts in his work shop.

Since he was 10 years old, Pat has been a collector of antique and vintage electronics. Not only does he collect televisions, but also radios, electronic fans, audio equipment, vintage military radios, and many “boat anchors”.

He is not only limited to black and white sets, but also collects color televisions and has a restored 1956 RCA CTC5!

Some of his rarer sets include a 1950 Rembrandt (Remington) and a 1949 Pilot model TV-125.

When asked about his most difficult television, he told me about a 1950 Stromberg Carlson model TC-10. It had a melted power transformer. Pat was able to restore it with a used Philco transformer! Having the ability to improvise is the mark of an excellent technician.

Thank you Pat for saving and restoring televisions. We need more people like you!

If you have any questions for Pat, he can be contacted at jmt71@optonline.net.



This wall of TVs include some of his favorites – the Bakelite Admiral and wood Motorola.



An 1948 Emerson Model 628 and a Pilot TV.



In this corner are the Rembrandt, Dumont "Dog House", Philco 52T1612, Philco 50T1203, and the RCA CTC5 color set.



Works "in progress" in the basement.



More works "in progress"



The work bench – more organized than most!



*Philco Model 48-1000. Just restored.
Waiting for the knobs.*



*1949 Crosley Model 9-403. Working
and in a blond cabinet.*

BOOK REVIEW

The Early Short Wave Stations

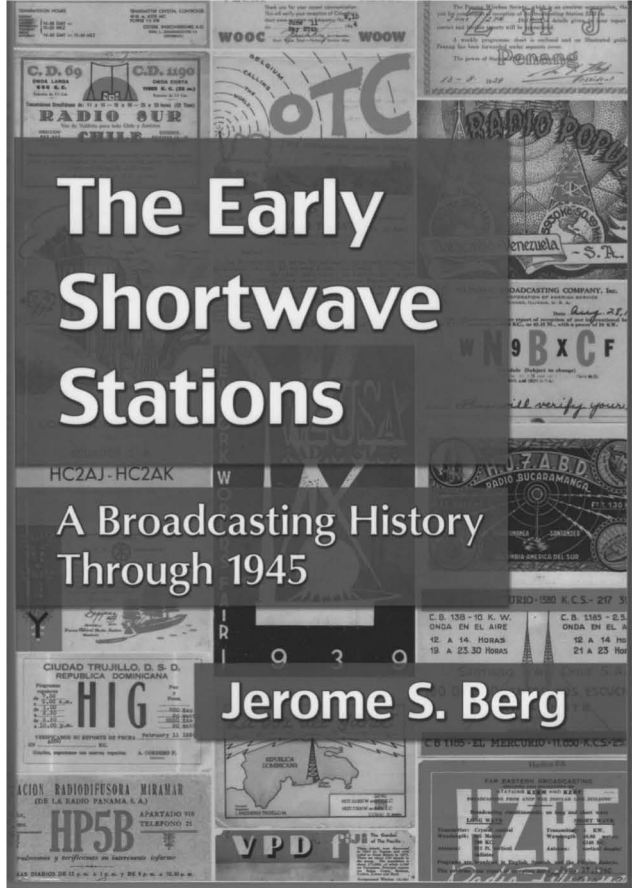
BY JEROME S. BERG
REVIEWED BY BART LEE

Jerry Berg writes great radio history. Whatever the period, the words of Hugo Gensback in 1926 resonate: "I cannot imagine any greater thrill, than that which comes when I listen, as I often do, to a station thousands of miles away. It is the greatest triumph yet achieved by mind over matter." (Jerry so quotes in an earlier book).

The fourth book on Short Wave Radio history is as good as it gets: *The Early Short Wave Stations*. He subtitles this: *A Broadcasting History through 1945*. This book closes the circle of listening and broadcasting from 1901 to now. He approaches short wave radio chronologically, telling this story year by year. He illustrates the stations and the industry, and some of the literature of short wave listening. QSL cards from now ancient and rare broadcast-

ers are abundant. Preliminaries come first of course (Marconi and de Forest), and then it's broadcasting in the ether. The higher frequencies of short wave radio --- higher than the broadcast band of 500 KHz to then 1500KHz -- enjoyed much more ionospheric skip at night and for

frequencies above 10 MHz, in the day as well. Broadcast band stations had been heard internationally in the 1920s. There wasn't much interference in those days. But the shorter-wavelengths, the higher frequencies, regularly leapt from continent to continent. Moreover, in the 1930s countries had much to say to each other on the radio, sometimes virtually shout-



ing. Both Fascism and Communism took to the airwaves before sending waves of troops against each other and into peaceful countries also.

Geophysics also played a role in short wave radio's development. As the book relates, short wave broadcasting took off in the late 1920s. The "Radio Craze" put a broadcast band receiver in almost every home. People had a growing interest in hearing more, even from other countries. Radio News in June 1930 reported, "The growth of interest in short-wave broadcasting is nothing short of phenomenal"; this is the quote with which Jerry introduces the decade of the 1930s. The sunspots accommodated: from 1925 through about 1931 the eleven-year sunspot cycle peaked. The emanations from the sun charged the ionosphere. The radio waves bounced around the earth.

As the 1930s progressed, geopolitics in Europe and Asia heated up. So did the ionosphere, rising from a low in about 1935 to a peak in about 1940, the start of World War Two. At home in America, on so many radios now with short wave bands, people now could listened directly to the convulsions of the world. So too through World War Two, the belligerents had at it, in the ether as well as on the battlefield. Americans on the home receivers could follow every short wave broadcast announcement from around the world. These came from every warring nation, including even Lord Haw Haw for the Nazis. This book details exhaustively what these stations had to say, and the technologies of how they said it, including frequencies and powers. (Much then happened after 1945, and Jerry has also turned his considerable skills to shortwave radio in the Cold War in his second and third books).

Jerry has now detailed the history of short-wave radio definitively, with this fourth of four books. Every radio history enthusiast should own these books. So should every library covering the history of technology have reference copies.

A great virtue of these four books is the detail provided in the notes and sources. If it happened in short wave radio, it's in these books. These books are great companions to the old radios, from the gleaming living-room consoles to the little tabletops with modest short wave coverage. All of these radios brought into our homes the whole world. We owe a debt of gratitude to Jerry Berg for documenting this age and telling its stories so well.

Soft cover, 118 photos, 340 pages. Appendix, notes, bibliography, index.

Prior books in the series are:

On the Short Waves, 1923 -- 1945, Broadcast Listening in the Pioneer Days of Radio (2007)

Listening on the Short Waves, 1945 to Today (2010)

Broadcasting on the Short Waves, 1945 to Today (2012)

The Early Short Wave Stations can be ordered through the Antique Radio Classified Book Store at www.antiqueradio.com.

Bart Lee, K6VK, Fellow of the California Historical Radio Society in History. Correspondence is invited: kv6lee@gmail.com.

Attention Subscribers: You can access a color version of this article on the A.R.C. website at www.antiqueradio.com.

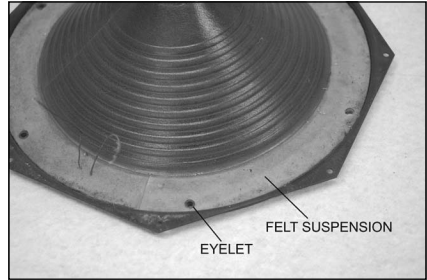
Repairing an Early Utah Drum Speaker

BY DANIEL SCHOO

Several years ago a friend of mine at work offered me a mid 1920's drum speaker in exchange for some audio tubes that he needed. I don't collect speakers nor do I have a radio that this speaker would work with but it aroused my curiosity. The lead wires measured 1000 ohms resistance so I knew the coil was not open but it didn't make any sound when I tried scratching the terminals of a battery with the lead wires. I'm always interested in antique technology and I'd never worked on a speaker of this type so I decided to see if I could fix it. It sat in the shop for a long time before I decided to get it out and see what was inside. I was aware of the workings of pre-voice coil dynamic speakers and from the look of this one it was a classic design using a balanced armature driver. I tried a web search on Utah speakers but I found nothing on this model.

The first problem was to figure out how to get it apart without damaging anything. Removing the metal grille plates from the wood frame revealed an inverted stiff paper cone with a felt strip around the edge as the suspension. The felt was eyelet riveted to the grille. A brass disk was glued to the center of the cone. A pool of solder in the center of the disk indicated the attachment to some kind of driver. I drilled out the six eyelets and removed the solder. The cone lifted off revealing a brass cup covering the driver. There was a small hole in the center of the cup with a small copper plated rod through it. Two nuts held the cup in place. As expected, under the cup was a balanced armature driver typical of these early electrodynamic speakers.

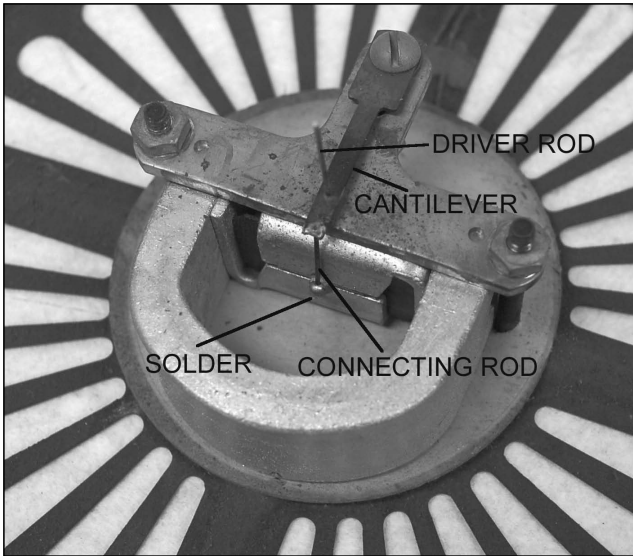
The basic balanced armature mechanism was invented in 1878 by Thomas J. Watson, assistant to Alexander Bell. It was first used as a sensitive telephone ringer¹. It is called a balanced armature because there is a small iron leaf with a pivot point in the middle, like a playground see-saw, balanced between the



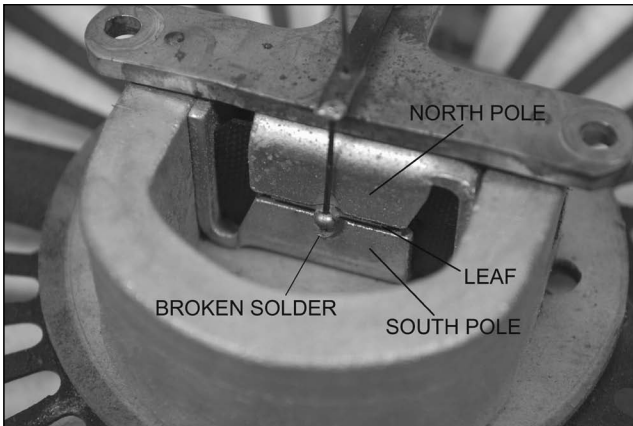
Closeup of the cone showing the felt suspension and eyelets.

poles of a permanent magnet. In the Utah speaker the pole pieces are arranged such that there is a north pole and a south pole above and below the leaf at each end. The poles on one end of the leaf are flipped top to bottom relative to the poles on the other end of the leaf. This sets up a field so that when the leaf moves, one end going up and the other end going down, both ends of the leaf always move toward the same magnetic pole. The leaf is held centered between the poles by a small rod soldered to a tab on one end of the leaf. The other end of the rod is attached to a cantilevered beam with an adjustment screw to adjust the height of the cantilever and in turn the position of the iron leaf between the poles.

Surrounding the leaf is a coil of wire. The coil carries the audio currents creating a magnetic field in the leaf that alternately adds to or subtracts from the permanent magnet field in proportion to the audio current strength and polarity. As it does the leaf is attracted and repulsed from the two magnet poles on each end with a force proportional to the strength and polarity of the audio currents. The movement is transferred to the cantilever beam through the connecting rod. Another rod attached to the beam connects to the center of the paper cone making the cone move along with the leaf. The cone couples the movement to the air to make the sound.



The balanced armature mechanism. The solder on the center connection rod has broken loose from the iron leaf.



Closeup of the balanced armature mechanism showing the broken solder on the iron leaf.

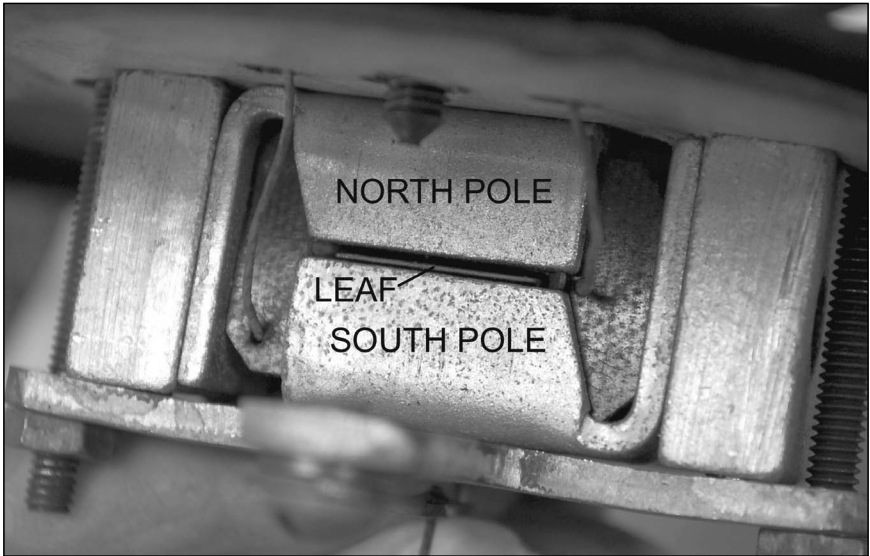
When I examined the mechanism it was easy to see the problem. The solder holding the connecting rod to the tab on the leaf had broken loose allowing the leaf to freely move and stick to one of the magnet poles. I disassembled the mechanism and removed it from the grille plate. There were some metal

filings stuck inside the magnetic gap. Two screws held the small horseshoe magnet in place. I removed the magnet and carefully degaussed the residual magnetism in the pole pieces and leaf with an old videocassette bulk eraser to release the particles. A little puff from a canned air duster safely removed what was left of the particles and dust.

I reassembled the magnet and put the mechanism back on the speaker grille plate. To get the iron leaf adjusted to the correct position I centered it between the magnet poles with a couple of paper shims. I reinstalled the adjustment screw and turned it so that the cantilever bar was in the center of the adjustment range. Then I soldered the connecting rod back onto the tab and resoldered the other end of the rod to the cantilever when I found that it too had a poor solder joint and was loose.

Now that the mechanism was reassembled I made the final adjustment to visually fine tune the leaf to the center between the magnetic poles. When the leaf was centered I locked the adjustment screw in place with the two jam nuts that were on it for that purpose. While the adjustment screw is accessible from the front grille of the speaker you cannot eas-

Attention Subscribers: You can access a color version of this article on the A.R.C. website at www.antiqueradio.com.

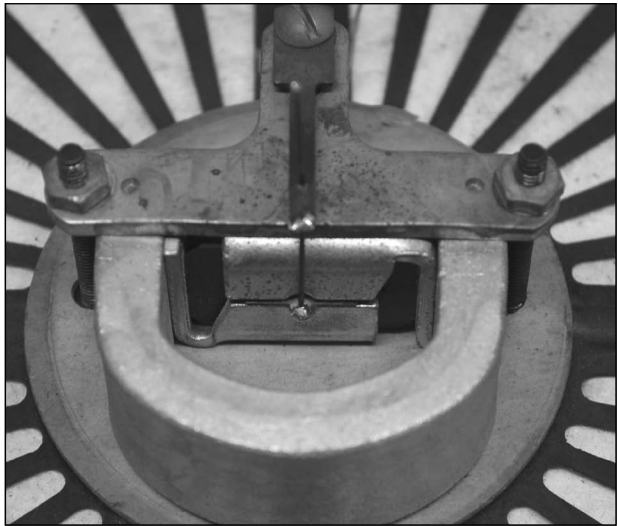


Closeup of the pole pieces showing the iron leaf between the gap. The coil surrounds the leaf.

ily make an accurate adjustment without having a good view of the leaf. You could probably adjust it by ear without taking the speaker apart but this would be only a rough adjustment and difficult to make.

All that was left was to do was reinstall the brass cup and the cone. Getting the rod from the cantilever bar lined up with the hole in the brass disk on the cone was a little tedious but it went in and I soldered it. I did not want to eyelet the cone back on the grille. This would not allow the cone to be easily removed again should something go wrong. I decided to try and match the look of the speaker by using 6-32 round head brass screws to reattach the cone. It worked quite well and in a few years after picking up a little patina the screws should look almost like original.

For a final test before putting the grilles back on the wood frame I got out a 9 volt transistor radio battery and scratched the wires to

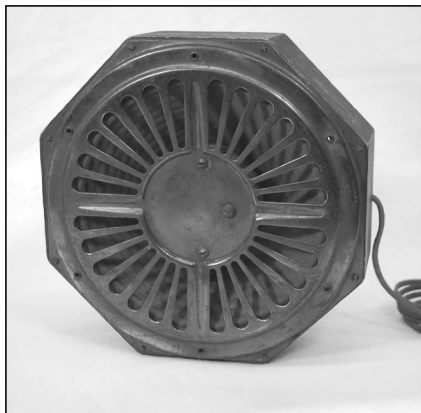


The mechanism after repair and adjustment.

the terminals of the battery. The scrape-scrape sound told me that the speaker was working. Later, after assembly, connecting the speaker to a radio confirmed that it was as good as new again.

References:

1. A History of Science and Engineering in the Bell System - The Early Years (1875 © 1925), Edited by M. D. Fagan, ©1975 Bell Telephone Laboratories Inc., P116



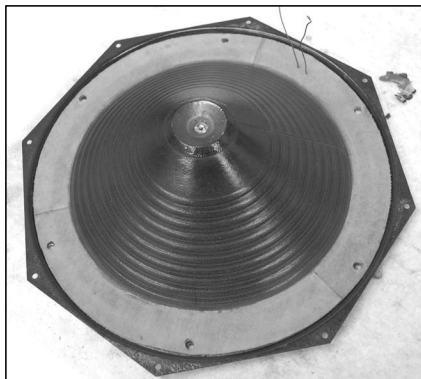
Utah drum speaker back view. The top and bottom screws in the center hold the balanced armature mechanism to the grille. The other screw to the center right is the leaf centering adjustment.



Utah drum speaker front view



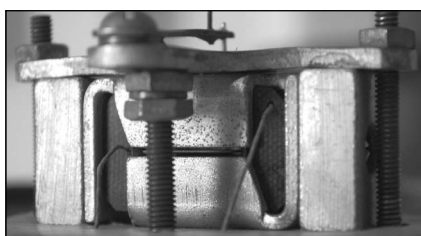
Front cover removed revealing the cone.



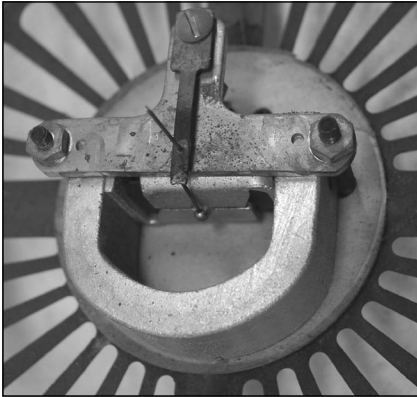
The paper cone in place ready to be fastened to the grille.



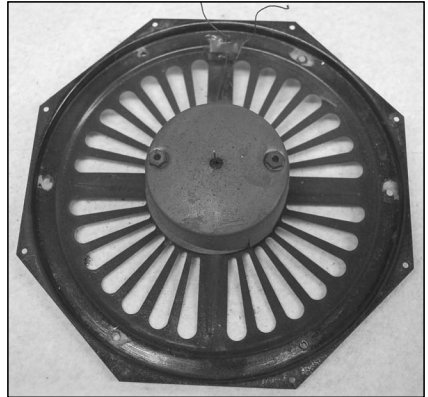
Closeup of the pole pieces showing the iron leaf held in position by paper shims



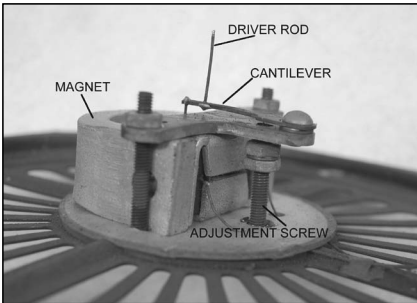
Closeup of the mechanism after repair and adjustment showing the adjustment screw and the iron leaf centered in the magnet gap.



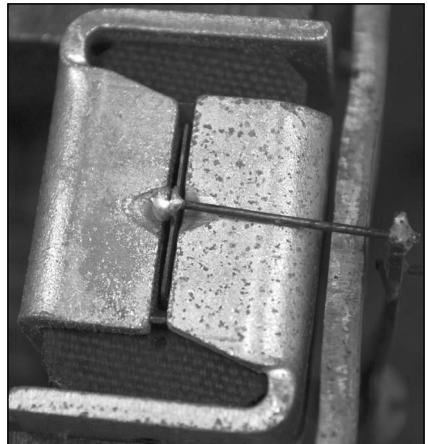
The balanced armature mechanism. The solder on the center connection rod has broken loose from the iron leaf.



The cove removed revealing the driver mechanism under a brass cover.



A side view of the balanced armature mechanism. The cantilever is on the top and the adjustment screw with jam nuts to the right.



Closeup of the balanced armature mechanism after resoldering the iron leaf.



Back view of the completed assembly showing the brass screws in place.

The Crosley 5-50

A Big Change For Crosley

BY DAVE CROCKER

First there was darkness.
Then there was light, followed by radio.

Almost all of the early battery receivers were manufactured with either hard rubber or Bakelite panels.

This continued up until 1926 until radio manufacturers turned to a more “softer” look and employed wooden panels, maybe to please the lady of the house. The Crosley Corporation’s last Bakelite-paneled set was their Trirdyn series of 1925. Earlier Crosleys, and most of all of the other radio manufacturers, had all their components bolted to the back of these Bakelite panels.

Early in 1926 Crosley marketed their Model 4-29 (the “4” stood for 4 tubes while the “29” meant it would sell for \$29), and also the 5-38 of which both sets would use slanted wooden panels and oval wooden lids to cover the tubes. These receivers were designed to “speak” through the Crosley Musicone paper cone speakers.

Then came the mid-year introduction of the 5-50 series of receivers. They operated on a TRF circuit with two RF stages, a regenerative detector and two audio stages. The tubes, (not included in the price), were all type 01-A’s. Physically these sets would all feature a new stamped metal chassis with everything bolted to it. Two main bolts were all one needed to remove this entire one-piece chassis. Gone forever would be the rigid bus-bar wiring system replaced now by cotton-covered flexible wires. These changes were somewhat of a breakthrough for radio manufacturing and was a first for Crosley.

Totally new for Crosley was a new one-dial system of tuning. It featured a thumbwheel type tuning method using a paper strip on which the owner could pencil-in their favorite station locations. Inside the set, this thumbwheel dial operated a ganged set of three open variable condensers. Two other small knobs (Crosley advertised them as “Crescendons”),



The Crosley Model 5-50 five-tube receiver of 1927.

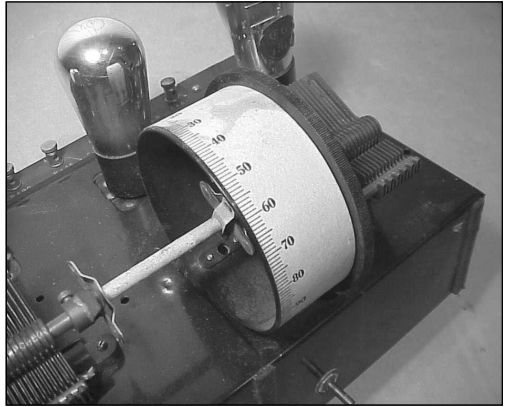
would adjust the filament voltages of rheostats on the chassis. Also, two vertical “sliders” (marketed as “Accumulators”), would be used for spider-web coil adjustments. Again, for sales purposes, the “5” meant the set would operate on five tubes and cost \$50. A companion 6-tube set, the Model 6-60, would use six tubes and cost \$10 more. The only difference here would be an added on-off switch just to the left of the lower left-hand filament knob.

This was followed by a real advancement, the first “batteryless” 6- tube Model AC-7 and AC-7-C (console), which were the first Crosley sets to operate on AC plug-in socket power. These radios would look very similar to the 5-50 series the major visible difference was the addition of a voltage meter just above the left slide control. These sets would have price tags of \$70 and \$95 respectively. Crosley would also offer (for \$50 additional), an A,B, and C power supply unit designed for use with these newly announced batteryless radios. Crosley had now joined the other radio manufacturers by offering AC receivers instead of messy, old DC battery sets.

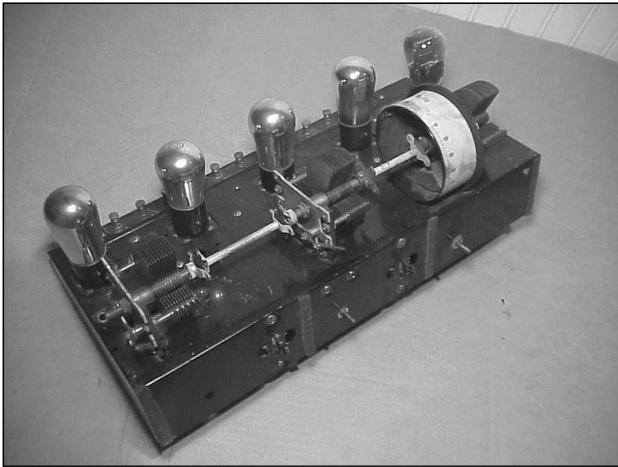
Wood paneling would finally give way to all-metal sets in 1927, the next trend in receiver design. Again, stamped metal chassis this time inside a metal cabinet, much like the

Atwater Kent Models 35, 40 and 42, etc. types. Crosley would call these sets the Bandbox, Jewelbox, Jembox and Showbox. These “boat-anchors”, as radio collectors would call them, would finally give way to beautiful, all-wooden cabinets by 1929. And that’s a good thing.

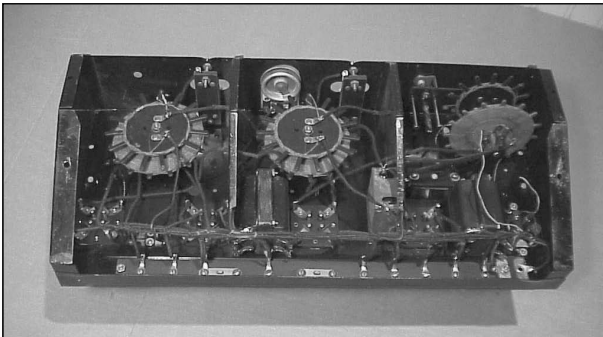
Dave Crocker, a graphic designer who retired from 31 years at the Polaroid Corporation, is also a semi-retired member of the A.R.C. staff. Dave has been collecting radios for over 42 years, and many of those years spent researching and collecting radios made by the Crosley Radio Company. Contact Dave at: 35 Santuit Pond Rd., #4B, Mashpee, Cape Cod, MA 02649. e-mail at Radio-1@comcast.net.



The thumbwheel drum tuning mechanism with a paper dial for jotting down favorite stations.



The stamped metal chassis of the Model 5-50.



Major Shootout of Best Performing 1930s High-End Radios

BY RICHARD MAJESIC

At the NMRCC October Radio Fest and rib eye steak feast, nine ultra-high end medium wave radios were evaluated for RF and audio performance. The radio receiving the highest score was the 1936 McMurdo Silver Masterpiece V in the Warrington cabinet. Second place went to a 1941 EH Scott AM-FM Philharmonic, even though it was from 1941 only the AM performance was evaluated and third place went to a 1935 Zenith Stratosphere 1000z. This event was another first for the radio collecting ecosphere and the NMRCC is proud to present this data to the high-end radio collecting world.

We selected eleven radio collectors - experts to perform the subjective evaluation that was based on three RF characteristics and three sound parameters, scoring was from 1 to 5, five being the highest. These radio experts own and listen too many of these same radios and are very familiar with the high level of performance these radios have.

Under evaluation were two EH Scott radios; an 1932 All Wave 12 Deluxe and a 1941 33-tube Philharmonic, one 1936 Midwest 18-tube model 18-36, three McMurdo Silver radios; 1932 Masterpiece II and two 1936 Masterpiece V models, one in the Clifton cabinet with the original 18" Jensen and the other in the Warrington cabinet with the optional pair of Jensen A12s and with a Jensen 5" "Q" tweeter; and three Zeniths; the 1935 Stratosphere model 1000z, 1936 Stratosphere model 16A61, and the 1938 model 15U269. All radios had been recently restored or serviced and were working as designed to their full performance levels.

To make this performance test objective the broad bandwidth SSTRans AMT-3000 transmitters were used. They have a 15 kHz audio bandwidth. All wide bandwidth radios were first tuned in narrow band to check RF characteristics and then to wide band for most of the audio assessments. Source music was '40s

NMRCC October Radio Fest 2013 - '30s Radio Ratings

Rater	EH Scott All Wave 12 Deluxe	EH Scott Philharmonic AM/FM	Midwest 18-36	McMurdo Masterpiece 2	McMurdo Masterpiece 5(1)	McMurdo Masterpiece 5(2)	Zenith Stratosphere 1000z	Zenith Stratosphere 16A61	Zenith 15U269
1	4.33		3.33			4.83	3.83	3.33	3.67
2	4.17	5.00	3.33		4.17	4.50	4.50	4.33	4.17
3	3.67	5.00		4.17	4.75	4.50	4.17	4.67	
4	3.20	4.50	3.67	3.80	3.67	4.40	3.60	3.60	
5		4.83	2.83	3.67	4.10	4.00	3.33	3.67	
6	3.67	4.33	2.33	3.00	4.00	4.83	4.50		
7	3.33	4.50			4.00	2.50			
8	4.50	5.00		4.50	4.17				
9	4.33	4.83		3.83	3.67				
10	3.17	3.67		3.00	3.33				
11	4.00	4.67	4.50	3.17	4.50	4.83	4.83	4.50	
	3.84	4.21	3.33	3.64	3.67	4.30	4.11	4.02	3.92
		2nd				1st	3rd		

and '50s popular music from CD and iPod players. All radios used the Grundig AN-200 loop antenna and it was tuned to the transmitter frequency before starting any evaluation. Every attempt was made to keep a level playing field for this evaluation; the only variable were the rooms these radios were located in - as small as 120 square feet with 8' ceiling to 750 square feet with a 14' ceiling.

On the bench the EH Scott Philharmonic was measured having 0.5uV for 30dB S/N while both McMurdo Silver Masterpiece V had less than 2% THD from the antenna terminals to the speaker voice coil at the equivalent voltage for 1 watt into 8 ohms. The smallest audio amplifier is in the EH Scott All Wave 12 Deluxe with 2 number 45 tubes in push-pull for about 8 Watts. The largest being the Zenith Stratosphere 1000z with eight number 45 tubes in push-pull parallel for 55

Watts. The majority of these radios used Jensen field coil speakers, the A12 or the 18" field coil speaker. The others used Magnavox 12" field coil speakers.

It was fun evaluation afternoon and you can see from the close scoring results that most of these radios are very good performers. They are beautiful examples of Art Deco design and accomplished woodworking craftsmanship. They are treasured and a pleasure to listen to on a regular basis.

Richard A. Majestic has more than 30 years of experience as a Broadcast Engineer. He holds ten patents for digital servo system designs, cryogenic instrumentation designs, and low noise analog circuit designs. He is a member of the New Mexico Radio Collectors Club.

NMRCC October Radio Fest

Score the radio's performance, 1-low 5-high

Rate the Radios' RF Performance:

1 2 3 4 5

- Tuning ease

- Tuning selectivity

- Noise rejection

Rate the Radio's Audio Performance:

1 2 3 4 5

- Audio quality, overall sound

- Audio power, turn it up

- Audio distortion, is there audible distortion



1936 McMurdo Silver Masterpiece V Console is overall winner of the NMRCC Shootout



The 1936 McMurdo Silver Masterpiece V placed First in both RF and Audio performance. It should be noted that this radio had the optional two Jensen A12 and 5" tweeter speakers which was available in 1937 for Public Address and home models in two cabinet styles, the Warrington cabinet and back.



The 1941 EH Scott AM-FM Philharmonic placed Second in both RF and Audio performance. It should also be noted that this 33 tube radio is from 1941 but only the AM was evaluated and it had the recent IF modifications and alignment which corrects the detected distortion problem in all Philharmonics.



The 1935 Zenith Stratosphere 1000z placed Third. It was rebuilt electronically and the cabinet expertly refinished in 2008 and performs well. It also uses two Jensen A12 and one "Q" tweeter speaker, which were standard for the Stratosphere in 1935.



The 1936 Zenith Stratosphere 16A61 placed Fourth. It was restored electronically in 2004 and placed in a 1933 Zenith cabinet.



The 1938 Zenith 15U269 ranked Fifth, it's has machine age deco styling and was electronically restored and cabinet refinished in 2009. It uses the 12" original Utah speaker with the diffuser, no tweeter.



The 1932 EH Scott All Wave 12 Deluxe ranked Sixth. It was completely disassembled, all metal parts re-chromed and re-assembled and aligned in 2010 and placed in a 1930s Philco cabinet, it has the original finish and uses a Jensen A12 speaker.



The 1936 McMurdo Silver Masterpiece II ranked Seventh. It was purchased, electronically restored and aligned in 2009. It is completely original with the exception of the cover being re-chromed, it has the re-coned 18" Jensen speaker and Clifton cabinet with the back.



The 1933 McMurdo Silver Masterpiece II ranked Eighth. It was completely disassembled, all metal parts re-chromed and re-assembled and aligned in 2011. The cabinet was originally fitted with the same model II radio and refinished in 2011 too.



The 1936 Midwest 18-36 ranked last. It's an 18 tube radio, purchased and electronically restored this year. It has the 12" Magnavox speaker.

The New England Antique Radio Club Radio XLV Meet

**FEBRUARY 16, 2014
WESTFORD, MA**

The New England Antique Radio Club held its annual radio meet in Westford, MA at the Westford Regency Inn on February 16, 2014.

This is New England's premier radio event that for many years was run by John Terrey of Antique Radio Classified magazine.

The meet attracted exhibitors and attendees from at least 7 states in the northeast and east coast section of the country. At least 400 people were in attendance. Even a snow storm the night before the meet couldn't keep people away from the event!

All 100 tables were sold out for the meet that took place in the hotel's Regency Ballroom, Whitter Room, and Emerson Room.

There was something for everyone to purchase at the meet. Wood and plastic ra-

dios from the 1920s to the 1950s, televisions from the 1940s, radio consoles, vintage audio equipment, books, tubes, parts, juke boxes, magazines, manuals, and much more – too much to mention.

One of the highlights of the meet was the presentation of the New England Antique Radio Club Life Member Awards presented to John Terrey, Ray Bintliff, Dave Sutherland, and Charlie Perkett.

The next NEARC radio meet is scheduled for April 26 in Brookline, NH. The special guest speaker will be Dr. Ralph Baer – the father of home video games!

If you ever have a chance to travel in the New England area try to arrange to attend a NEARC radio meet. They are well organized and you will have a wonderful time!



A nice collection of wood cathedral and tombstone radios.



A rare wood bookcase radio.



A 1920s A. Atwater Kent breadboard battery set.



Catalin, Bakelite, and battery set radios.



The Radio Orphanage had an excellent selection.



A Wurlitzer Jukebox.



More rare wood radios.



Life Member presentation ceremony.



A 1940s National wood television.



Ray Bintliff with some unique radios.



Anyone need a catalin radio?

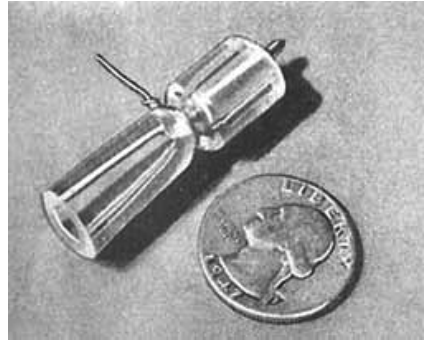
The DuKane Ionovac Speaker

BY DANIEL SCHOO

Back in the early 1950's the new trend of High Fidelity sound in the home had its beginnings among manufacturers and consumers. Except for motion picture theaters, stereophonic reproduction had not yet become commonplace but the quest for more natural realistic sound reproduction was gaining rapid popularity. In 1954 the DuKane Corporation in St. Charles Illinois became interested in developing an entirely new form of sound reproducer, called the "plasma speaker", as a product. The plasma speaker is quite different from the usual cone or horn speaker. In the plasma speaker there are no moving parts. The sound is generated by the interaction of air with high temperature plasma contained inside a small open ended quartz tube called a "cell". The quartz tube is coupled to a small horn much like other conventional horn speakers that use a magnetically driven diaphragm.

The plasma is formed at the end of a sharply pointed electrode placed inside the acoustic focal point of the cell. To create the plasma, a high voltage radio frequency signal operating at 27.12 megahertz is applied to the electrode. The RF field intensity at the tip of the electrode is so high that it causes the air to ionize and form a bluish purple plasma discharge. The RF is modulated by the audio signal causing the size of the plasma field to increase and decrease in direct proportion to the audio. As it does, it compresses and rarefies the air inside the cell around the plasma causing compression waves. The waves travel down the horn and exit into the room as sound.

DuKane became involved with the plasma speaker when inventor Siegfried Kline contacted William Torn of DuKane and made a proposal to have DuKane manufacture his invention. Torn was very interested and invited Klein to demonstrate his speaker which Klein called the Ionophone. Torn was so impressed with the demonstration he convinced the DuKane management to create a new division to develop and manufacture the Ionophone re-



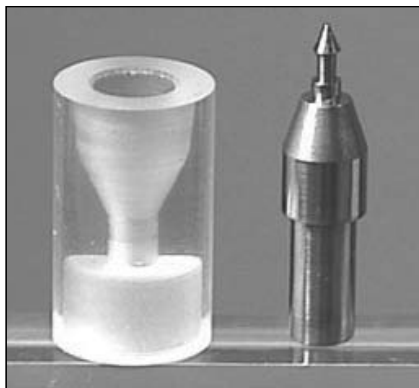
Model T-3500 cell assembly.

naming it to Ionovac. Torn was appointed the Ionovac Division Manager and put together an engineering team to assist Klein in developing the concept into a mature product.

In mid 1957 DuKane announced the first Ionovac Model T-3500 in a series of magazine articles and advertisements. It used a transformer based power supply and three tubes; a 5U4GA rectifier, 12AX7 preamp / modulation driver and a 6146 power oscillator. The power supply and oscillator were mounted on one rather bulky chassis with the cell and horn assembly mounted on another small chassis. The two were connected together by a long twisted pair shielded cable.

A production run of five hundred T-3500 speakers were manufactured under a cooperative agreement with Electro-Voice. It was called the model T-3500 because the speaker was a tweeter and used a crossover frequency of 3500Hz. Electro-Voice packaged it in their high end Patrician speaker system. It was also available for purchase separately for \$147.00 each. Because there were no moving parts and no mechanical inertia the T-3500 had a frequency response and freedom from resonances that was unheard of in its day extending far into the ultrasonic range.

While the T-3500 sounded spectacular it continued to suffer from startup and reliability problems. The cell in the T-3500 was made of



Final version of the cell kit. Quartz cell on the left, and replaceable electrode on the right.

a high temperature glass called Vycor®. Vycor® tubing was cut to length, an electrode was inserted inside and the tubing was heated to the softening point. The tubing was then necked down around the electrode to form the cell assembly. The cells were all handmade and no two were exactly the same.

Cell failures from electrode sputtering and fouling were common. The plasma often did not start or maintain due to changes in the radio frequency resonance of the cell as it heated up. Improved designs for the cell and the oscillator were tried but they were no more than a band-aid fix to a product that needed a fresh approach. By May of 1959 a consumer magazine called the Ionovac a brilliant failure. The T-3500 was discontinued shortly after that time but DuKane was convinced in the viability of the product and continued development.

After extensive research and testing in co-operation with the Illinois Institute of Technology Armor College of Engineering, Materials Engineering Department, DuKane settled on a ground quartz cell with a replaceable electrode assembly. The new electrode material was a high temperature alloy called Alkrothal 14 manufactured by Kanthal AB in Sweden. DuKane invented and patented a totally new method of grinding quartz using ultrasonics in order to manufacture the cells cheaply. The electrodes were turned using conventional screw machine methods. The cell assembly slipped into a ceramic sleeve mounted to the back end of a small cast aluminum horn. The cell was held in place by a high temperature glass bonded mica material called Supram-

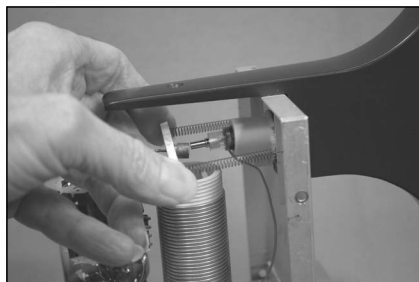
ica®. The power oscillator was immediately behind the horn on a small aluminum chassis totally enclosed by a perforated aluminum cover for safety and to prevent RF radiation.

The frequency drift problem was solved by incorporating the cell into the frequency determining circuit of the oscillator rather than just coupling the oscillator output to the cell in a separate resonant circuit. As the cell warmed up, changes in the capacitance pulled the oscillator along with the resonant frequency of the cell.

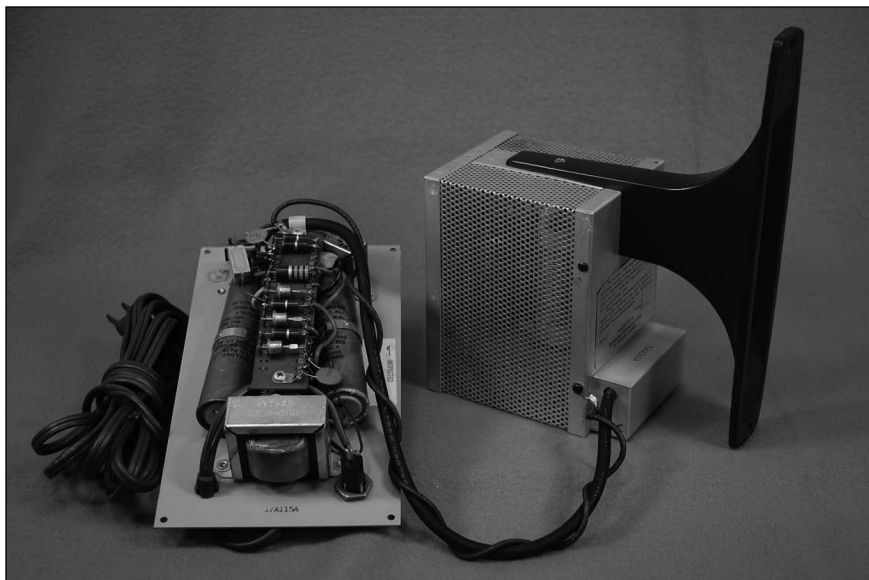
The improved production design used a simplified circuit with only one tube; a type 6DQ6A beam power tube as the power oscillator. The 6DQ6A was commonly used as a horizontal output tube in black and white TV sets. It was cheap, plentiful and had the advantage of requiring only 150 volts of screen bias making screen modulation easier with lower audio voltages.

The power supply was built on a separate chassis and connected to the oscillator chassis by an umbilical cable. The design was a simple compact transformerless voltage doubler type using silicon rectifiers and operating directly off of the AC power line. A filament transformer powered the tube heater. A small modulation step up transformer coupled the audio directly to the screen grid of the oscillator to modulate the RF. The modulation transformer was the primary limiting factor of the frequency response. The speaker itself was capable of reproducing well over 100 KHz. The cell life of the new model was far better and user replaceable cell kits were cheap. The plasma startup was reliable and consistent.

Two models of the new Ionovac were built beginning in late 1960. Both of them used identical circuitry and hardware with a few



Cell assembly held in place by a ceramic bar and springs.



The model 14A435 Ionovac speaker.

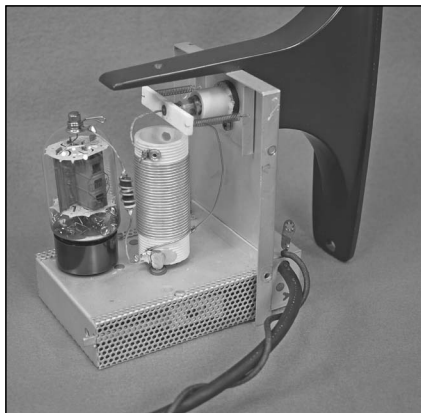
minor differences. The 14A430, called the basic model, had the power supply totally enclosed in a metal box. The oscillator horn chassis had a six foot connecting cable that plugged into a socket on the power supply. The 14A435, called the system model, had the power supply mounted on an open face metal plate. A sixteen inch permanently attached cable connected the oscillator horn chassis to

the power supply.

The new Ionovac was first demonstrated at the New York Hi-Fi show in September of 1960. In the words of one of the DuKane engineers who attended the show it was “a big hit”. It was far more reliable; it had a clean pure sound and got good reviews from audio publications. In August of 1961 a final production run of the new improved Ionovac was



The model 14A435 Ionovac speaker.



Inside the model 14A435 oscillator chassis.

made. It is unknown how many were made but serial numbers up into the 1600's have been seen. DuKane sold the Ionovac tweeter separately and in combination with midrange and woofer speakers in prepackaged systems from small bookshelf to floor standing towers.

DUK-5 A basic model 14A430A Ionovac tweeter. Frequency response was claimed at 3500Hz to 30 KHz \pm 3db and the entire unit weighed 4 pounds. It sold for \$69.50.

DUK-10 A system model 14A435A Ionovac unit packaged in a wood cabinet with a plastic waffle grille. Frequency response was claimed at 3500Hz to 30 KHz \pm 3db. It mea-

sured 13.5 inches high, 5.25 inches wide by 11 inches deep and weighed 7.5 pounds. It sold for \$79.50.

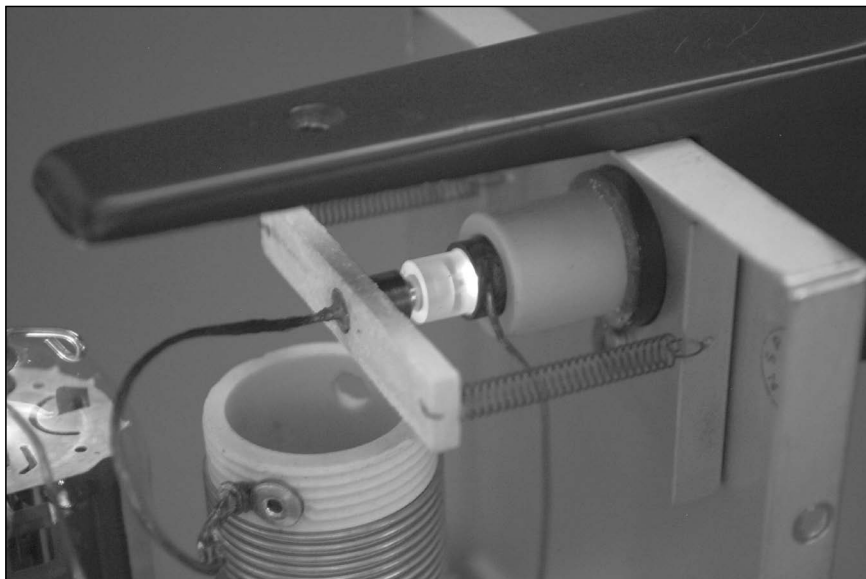
DUK-15 The same as a DUK-10 with the addition of a 9A775 crossover kit factory installed in the back of the cabinet. It sold for \$99.50.

DUK-20 DuKane's larger "bookshelf" full range system that could be used alone or placed horizontally free standing on the floor with the optional 22 inch high leg kit. It was rather big for the typical bookshelf at 30 inches high by 14 inches wide by 13 inches deep. This one was a three way using a 14A435A Ionovac tweeter, two 3.5 inch closed back midrange and one 12 inch woofer. Frequency response was claimed at 40Hz to 30 KHz with no limits of deviation given. It sold for \$187.50. The optional legs were available for \$15.00.

DUK-30 The mid size of three column systems available. The speaker lineup was the same as the DUK-20 put into a larger corner fitting column. The 12 inch woofer and two 3.5 inch closed back midrange drivers were mounted in a sealed ducted port lower section. A 14A435A Ionovac was in a separate open upper section with the characteristic waffle grille in front. A 9A695 two way crossover network with an adjustable L-Pad on the tweeter feed was mounted in the up-



The Ionovac speaker seen in operation.



The bluish purple glow of the cell.

per chamber on the back panel. The 9A695 crossover had a similar construction to the 14A435A power supply. It was assembled on an open face plate that was mounted flush in an opening of the back of the upper section. It had a terminal strip on the back for connection to the amplifier and pigtail wires for connections to the speakers. A separate high pass network was connected to the midrange speakers in the lower section with a crossover of 800Hz. Frequency response was claimed at

40Hz to 30 KHz with no limits of deviation given. The cabinet was 48 inches high, 15.375 inches wide by 11 inches deep and weighed 45 pounds. It sold for \$199.50.


DUK-40 This was the smaller tower system. The construction was similar to the DUK-30 but it was only two way. It used a 14A435A Ionovac above and a single 8 inch woofer below. Frequency response was claimed at 55Hz to 30 KHz with no limits of deviation given. It measured 37 inches high, 12.5 inches wide by 9.5 inches deep in a corner fitting column. It sold for \$149.50.

DUK-50 The smaller two way bookshelf system with an 8 inch woofer and a 14A435A Ionovac. Frequency response was claimed at 55Hz to 30 KHz with no limits of deviation given. It was far more suited for bookshelf placement measuring 11.5 inches high by 24 inches wide by 12 inches deep and weighing 30 pounds. It sold for \$139.50

DUK-60 This was the big daddy top of the line tower system similar to the DUK-30 but with a larger midrange driver and an unusual compliment of two woofers. It used a 14A435A Ionovac up above in the open section. The lower section used one 8 inch midrange with its own level adjustment. Also down below were an 8 inch woofer and a second 12 inch woofer to round out the response. The frequency response was claimed to be 40



The Ionovac speaker seen in operation with the bluish purple glow of the plasma.

FEATURING THE  **IONOVAC** *— true sound reproduces enclosed in custom made enclosures to reach any door.*

DUK-30 **DIAPHRAGM TWEETER**
This unit is designed to improve existing high fidelity speaker systems or to serve as a replacement. It features a diaphragm of accurate bias. It will function on a bench or in an enclosure of high fidelity quality.

DIMENSIONS: 12" high, 8 1/2" wide, 11" deep.

VENTILATION: Designed and constructed for proper mounting.

IONOVAC CELL: The ionovac cell is a precision ground and constructed for the work.

WOODS: Walnut, cherry, mahogany, blond and unfinished.

FINISH: Modern decorator finish.

DUK-30 **WIDE RANGE SPEAKER SYSTEM**
A complete wide range, high fidelity speaker system featuring the Ionovac tweeter, speaker and Ionovac cell. The Ionovac wide bandwidth reproduces all frequencies from 20,000 and above, for high range speakers covering 200 Hz to 15,000 cycles, and a 200 Hz to 15,000 Hz range.

DIMENSIONS: 18" high, 14" wide, 17" deep.

VENTILATION: Designed and constructed for proper mounting.

IONOVAC CELL: Precision ground for extra long life and an exceptionally quiet and accurate audio reproduction.

WOODS: Walnut, cherry, mahogany, blond and unfinished.

MOUNTING: DUK-26 can be mounted on a wall, floor, or speaker enclosure or, through a hole in the wall, floor or ceiling.

FINISH: Modern decorator finish.

DUK-31 **WOOD GRAIN COLUMNAR**
A completely designed columnar system provides wide range sound reproduction. It features the Ionovac tweeter, speaker and Ionovac cell. The Ionovac wide bandwidth reproduces all frequencies from 20,000 and above, for high range speakers covering 200 Hz to 15,000 cycles, and a 200 Hz to 15,000 Hz range.

DIMENSIONS: 48" high, 10" wide, 12" deep.

VENTILATION: Designed and constructed for proper mounting.

IONOVAC CELL: Precision ground for extra long life and an exceptionally quiet and accurate audio reproduction.

WOODS: Walnut, cherry, mahogany, blond and unfinished.

FINISH: Modern decorator finish.

DUK-40 **STEREO WIDE RANGE SPEAKER SYSTEM**
A "Cathartic" full range stereo speaker system. Features the Ionovac tweeter, speaker and Ionovac cell. The Ionovac wide bandwidth reproduces all frequencies from 20,000 and above, for high range speakers covering 200 Hz to 15,000 cycles, and a 200 Hz to 15,000 Hz range.

DIMENSIONS: 48" high, 10" wide, 12" deep.

VENTILATION: Designed and constructed for proper mounting.

IONOVAC CELL: Precision ground for extra long life and an exceptionally quiet and accurate audio reproduction.

WOODS: Walnut, cherry, mahogany, blond and unfinished.

FINISH: Modern decorator finish.

EVERY IONOVAC UNIT IS BACKED BY A FULL YEAR WARRANTY FROM DUKANE

IONOVAC DIVISION DUKANE CORPORATION St. Charles, Illinois

Sold through the following authorized dealer:

IONOVAC HIGH FIDELITY AND STEREO SPEAKER SYSTEMS

Unequaled design and performance from 475

Inside an Ionovac sales brochure.

Hz to 35 KHz \pm 4db with crossovers at 3500 and 800Hz. The cabinet measured 51 inches high, 21 inches wide by 13 inches deep and weighed 68 pounds. It sold for \$246.00

438-37 Replacement Cell kits sold for \$9.00

9A775 Crossover Network kit was a two way crossover for adding an Ionovac tweeter to an existing system. The kit consisted of a 9A770 3500Hz crossover and a 99A235 8 ohm L-Pad. The 9A770 crossover was totally enclosed in a metal box and had a set of screw terminals to attach the speakers and amplifier. The kit sold for \$20.00.

438-44 Custom Wood Grille kit was offered for those who wanted to build their own enclosure, as many did in those days. It consisted of the characteristic white plastic waffle grille and an attractive wood frame to hold it. The kit was designed to mount in the rough opening of a home built enclosure or room wall. This was a nice addition to the product line because it allowed the Hi-Fi owner to add an Ionovac to a custom speaker system and maintain a professional finished off appearance. The grille sold for \$7.50.

Even after improvements made the Ionovac more reliable, disappointing sales forced DuKane to discontinue production. Rather than continue development to decrease costs and improve reliability they decided to close the Ionovac Division in late 1962. Remaining Ionovac systems were sold off direct to the public from the St. Charles warehouse and unsold stock was scrapped. Replacement cell

THE SEAL OF CERTIFICATION FROM THE FINE HARDWOODS ASSOCIATION

suddenly the air becomes alive with sounds you've been missing from your records, tapes and tuner!

Because we've been an early adopter, genuine hardwoods reveal infinite and subtle variations in color, grain and figure. This uniqueness distinguishes the products from the competition. Handcrafted niches and character... a near ending source of pride and satisfaction. Look for this seal on an Ionovac cabinet.

EVERY IONOVAC UNIT IS BACKED BY A FULL YEAR WARRANTY FROM DUKANE

IONOVAC DIVISION DUKANE CORPORATION St. Charles, Illinois

Sold through the following authorized dealer:


IONOVAC HIGH FIDELITY AND STEREO SPEAKER SYSTEMS


The outside of an Ionovac sales brochure.

kits were available for a few years and finally dropped as an obsolete part.

Today some of the Ionovac speakers survive and are highly prized by high end audio enthusiasts. The electrodes are considered consumable and do eventually wear out. Cell kits are very rare. Up until recently high quality modern reproduction cell kits were available on the web from a private individual but that supply has dried up. The quartz cell is fairly robust and can be reused with several changes of electrodes. New electrodes are not exceptionally difficult to manufacture on a lathe. The original Alkrothal 14 alloy is still available but it is uncommon and difficult to find. Fortunately the easily available alloy of type 304 stainless steel makes an excellent long life electrode material. In life tests I have observed useful service of over 10,000 hours on 304 stainless electrodes. Frequent startups shorten the life of the electrode.

The worst thing that you can do to an Ionovac in normal usage is overdrive it. An input voltage of over the recommended maximum of .750 volts RMS will rapidly increase distortion and cause parasitic oscillations. At 2.16 volts RMS the oscillator is at 100% modulation and seriously distorting. Overdriving the Ionovac risks flashing over the screen bypass feedthrough capacitors on the oscillator unit and can impose serious damage to the modulation transformer. The transformer will flash over internally causing a turn to turn or primary to secondary short. This is doubly dangerous because the modulation transformer



IONOVAC DATA SHEET 

GENERAL DESCRIPTION

The Ionovac DUK-10 is an old-on-heater section designed to improve exciting high fidelity speaker system.

The Ionovac is housed in a distinctive enclosure employing an acoustic lens. This unit can be mounted on a book shelf or on top of a high fidelity console type speaker.

FEATURES


DIMENSIONS: 13-1/2 inches high, 5-1/4 inches wide, and 11 inches deep. The power supply is located in the speaker baffle.

VENTILATION: Designed and engineered for maximum ventilation regardless of mounting.

IONOVAC CELL: The Ionovac cell is precision ground for extra long life and unconditionally guaranteed for 1200 hours.

WOODS: Walnut, cherry, mahogany, blond, and unfinished.

FINISH: Modern decorator tones.



Ionovac model DUK-10 data sheet.

isolates the AC power line from the audio input. Should the transformer short it can apply 120VAC to the audio input causing a shock hazard and serious damage to any equipment connected to the speaker.

***IMPORTANT SPECIFICATIONS:**

Sound Output:

.75 volt RMS continuous sine wave input = 95db at 1.5 ft on horn center axis

Frequency Response:

±3 db from 3500 Hz to 30 KHz

Operating Input Impedance:

At 200 Hz = 5.1 ohms

From 1 KHz to 20 KHz = 8 ohms +0, -0.8 ohms

At 30 KHz = 6.30 ohms

Non-Operating Input Impedance:

At 200 Hz = 8.6 ohms

At 5 KHz = 182.6 ohms

At 20 KHz = 43.7 ohms

Input voltage into 8 ohms:

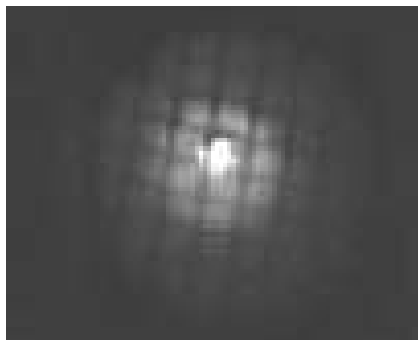
0.75 VRMS sine wave/1.06 V Peak = recommended for maximum undistorted output

1.50 VRMS sine wave/2.12 V Peak = 50% modulation

1.75 VRMS sine wave/2.47 V Peak = maximum input without parasitic oscillation

2.16 VRMS sine wave/3.05 V Peak = 100% modulation, absolute maximum input voltage

*Ratings given are for a typical speaker with a new electrode. Your speakers may vary due to the individual characteristics of the oscillator tube and/or cell condition.



View of the Ionovac plasma down the throat of the horn.

References:

US Patent #3,105,124, "Inertialess Transducer" granted to William R. Torn September 24, 1963.

DuKane speaker data sheets 9A775, 14A430, DUK-10, DUK-20, DUK-30, DUK-40, DUK-50 and DUK-60 all undated.

DuKane "High Fidelity & Stereo Speaker Systems" price sheets, forms 8018-I-60A, 8018-H-61 undated.

DuKane sales brochures forms 8012-H-60, 8011-H-60 undated.

DuKane DUK-5, "General Instruction Manual" undated.

DuKane DUK-10, "General Instruction Manual" undated

DuKane DUK-15, "Installation Instructions" undated.

DuKane DUK-50, "Operating Instructions" undated.

Electro Voice model T-3500 "Specifications and Instructions" (tentative) part no. 53518, dated December 13, 1957.

Essay by William Torn, untitled, undated, covering the origin and technical operation of the DuKane Ionovac tweeter.

"The Driverless Tweeter From Paris" High Fidelity Magazine, January 1961, by Norman Eisenberg.

"Ionovac Speaker: Still a Brilliant Failure", Consumer Reports magazine, May 1959.

"Care and Maintenance of DuKane Ionovac Tweeters" Daniel Schoo, October 2002, revised December 2003.

Kanthal AB data sheet, "Alkrothal Strip Ferritic Resistance Alloys", 1997-01-30, Issue 3, undated.

Kanthal Handbook "Heating Alloys for Electric Household Appliances" catalog 1-A-4-3, undated.

Daniel Schoo is an electronics design engineer at Fermilab in Batavia Illinois. His main interest is in restoration of antique radios. He can be reached at xenongas@hotmail.com.

An e-Embarrassment of Riches

BY DAVE SICA

Antique Radio Classified is now delivered monthly online and the print version to quarterly distribution to subscribers. This is a difficult situation and has understandably caused some complaining. Based on the “traditional” model of receiving a PDF file via email and viewing it on your computer screen, most people I know prefer receiving a traditional copy of a magazine in the mail versus online. Somehow the perceived value of a printed magazine is high and the perceived value of an online magazine is less. I know that any time I have a choice I’ve always preferred to have a printed magazine to read at my leisure in my library. For me, it was always too much of a “deal killer” reading from my computer or laptop’s screen; it just seemed like too much of a hassle. I all but ignored online delivery options; I made an exception for our club newsletter, the “NJARC Broadcaster” but I sympathized with folks who preferred receiving the real thing.

But things have changed dramatically for me: I recently bought an iPad. Not even a fancy new model, just a creaky old first generation one for about a hundred bucks on eBay. The “killer app” for reading online magazines is using an e-reader. The difference is like night and day. With that, my PDF copy of our club newsletter now presents nearly the same reading experience as the paper copy. I still get the daily newspaper delivered, but half the time I forget to go pick it up at the end of the driveway; I’ve come to find reading it online is actually a better experience. This goes the same for A.R.C.

Many collectors are notoriously, er, thrifty and spending significant money on an iPad just to read a magazine so that it doesn’t have to be printed and mailed to them is probably going to seem like a nonstarter. But it’s not just A.R.C. The volume of material that is available on the Internet has become vast. The number of radio books and magazines that have become available for free has mushroomed over the past few years.

One new site in particular, www.american-radiohistory.com, has forcefully tipped the scales in favor of making a cheap iPad look

like a great investment. This site offers nearly every issue of nearly every old radio magazine I’ve ever seen, plus more. Many of us have invested in back issues of Radio News and Radio-Craft. Let’s do some math: if you bought these magazines for the going rate of perhaps five or ten dollars an issue, by the time you had collected over twenty issues, you’d be financially better off investing in the iPad. And even if you only paid less than a dollar per issue like I did, you would still have to invest hundreds of dollars to get anywhere near a complete set. I figure that even at a dollar an issue (and that would be a nearly impossible feat any more) accessing the online archive means you will avoid spending over \$700 for just those two titles alone, and there are hundreds and hundreds of other great magazines on the web site. At perhaps a more realistic \$5 per issue, you’ve have over three thousand dollars worth of antique radio magazines in just those two titles alone, all accessible via your hundred dollar investment in a tablet.

Did I mention that those hundreds of magazines will all fit into an e-reader at the same time? A reader weighs about the same as a book, yet I have my choice of dozens of magazines, books and schematic diagrams (along with music and movies) at my fingertips whenever I want. I’m still impressed by that!

There are hundreds of other great textbooks and magazines available online at places like the Internet Archive (www.archive.org) and elsewhere. There is literally a lifetime of great reading now available for the asking. These are indeed very interesting times for the radio historian.

And perhaps the best news is that after you have justified the purchase of a reader that way, you will now be able to read A.R.C. on your iPad. Sooner and in color. And you can continue to enjoy this great radio magazine every month even as the new reality of the publishing business makes printing and mailing monthly issues less and less.

Dave Sica is a lifelong collector of antique radios and televisions and is a founding member of the New Jersey Antique Radio Club.

A.R.C. ANNOUNCES

Get Ready for the Third International Restoration Contest

Turn Junk to Mint

BY STAFF

Once again, Antique Radio Classified is proud to announce the third annual International Restoration Contest.

For the past eleven years, the Quebec Antique Radio Collectors Society (SQCRA), a group of collectors mostly from the Canadian province of Quebec, has been holding a radio restoration contest for its members. For the third time, they're taking the challenge to an international level, inviting all interested clubs to participate in the International Restoration Contest. The contest will end on March 15, 2015 and judging will be final on March 30, 2015.

We are looking forward to publishing the results of the second contest within the next few months.

Maybe you already have a restoration contest in your club. It would be interesting if all clubs join this international event, perhaps following your own local competition. This may be the perfect way to spur new friendships, stimulate exchanges between clubs, and promote conservation of antique radios through their restoration.

The rules are simple: interested participants have one year to restore a basket case radio. Photographs must be taken before the restoration starts and at all steps of the process. One year later, the participants must present their work to a panel of judges in a local club event. Photographs taken during the process will help judges better understand the challenges participants faced in order to finish

their projects. The individual clubs may give a prize (perhaps a free one-year membership) to the local winner. The criteria for evaluation are submitted beforehand to all the clubs interested and are subject general consensus. Once every club has finished its local contest and determined the winner, a pool of all the first prizewinners would be created and submitted to an international panel of judges. This panel would comprise one member elected locally from each participating club. Pictures from each contestant would be submitted through the Internet to each judge and results compiled to determine a winner and two runners up. The clubs that don't have a contest could nominate someone

to represent their club at this contest.

The goal, of course, is to promote the conservation of the technological/historical heritage, to motivate our common interest, increase the general knowledge of antique radio technology, increase club exchanges, and see what is done in other clubs.

If you are interested in participating, contact the SQCRA—they would be happy to include your club in this new international event. As a first step they will create a list of all participating clubs. Afterwards, they will invite all organizations to provide the name and email address of the selected judge who will become the contact for the club in order to create the international panel.

Contact Information

Quebec Antique Radio Collectors Society (SQCRA)
538 Judd, St-Eustache
Quebec, Canada J7R 4N8

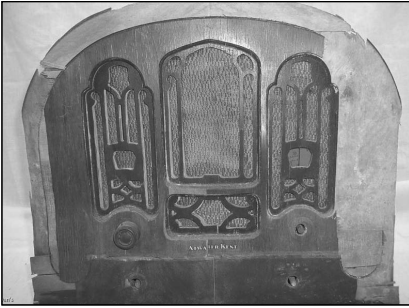
Contest Contact: Serge Hainault, sireno@live.ca
Club President: Daniel Labelle, dlabelle54@videotron.ca
Club website: www.sqcra.org
Contest page: www.sqcra.org/interrestocontest/international_rc/internationalrestocontest.html



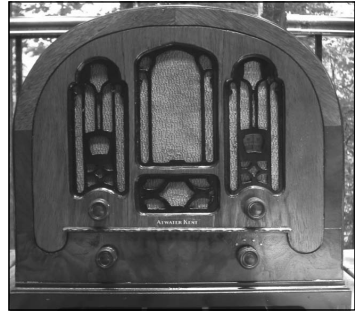
Results of the First International Restoration Contest

First Place

Daniel Koczur of the Mid-Atlantic Antique Radio Club for his restoration of the Atwater Kent Model 708 cathedral radio:



Before Photo



After Photo

Second Place

The New Zealand Vintage Radio Society and the restoration of a Philco Model 18 cathedral radio:



Before Photo



After Photo

Detailed information and complete photos can be found on the SQCRA web site at <http://www.sqcra.org/interrestocontest/International%20resto%20contest%20results%202012-2013.html>.

Photo Review

Silvertone Communications Receiver – model number unknown. Manufactured in 1940. There are 9 tubes. Covers 1.7 Mhz to 30 Mhz. Kevin Turney, Battle Creek, MI.



Lafayette "Professional 9" Receiver – Has 4 bands that cover 1.7 Mhz to 30 Mhz. Made during the 1930s. Eye tube was added at a later date. David Brackett, El Dorado, CO.

Hallicrafters Model SX25 Receiver – The "Super Defiant". 4 band general coverage receiver. Pedro Camacho, Los Angeles, CA.

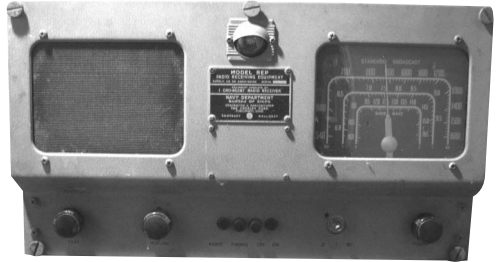


Photo Review



Heathkit Model FM4 FM Tuner – Early FM tuner from Heathkit. There are 5 tubes. Manufactured about 1960. Steve Goh, Sioux Falls, SD.

Navy Department Model “REP” Receiver – Radio receiver CRO-46287. There are 3 bands: BC, SW1: 6.0 Mhz to 10 Mhz, and SW2: 10 Mhz to 15.5 Mhz. With eye tube. Landon Jeffers, Charlotte, NC.

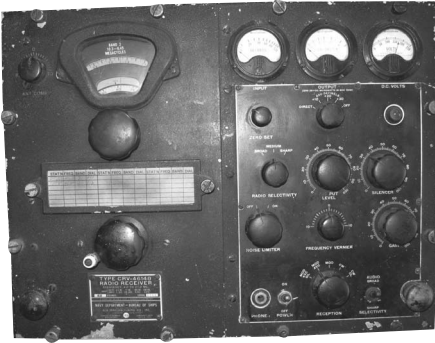


RCA Model SC88 Receiver – US Army Signal Corps R-320/FRC. Roy Nester, Tallahassee, FL.

Pilotone Model AA903 – This is an audio amplifier. Uses 2 6V6 output tubes. Runs approximately 15 watts output. Chris Ponce, Austin, TX.

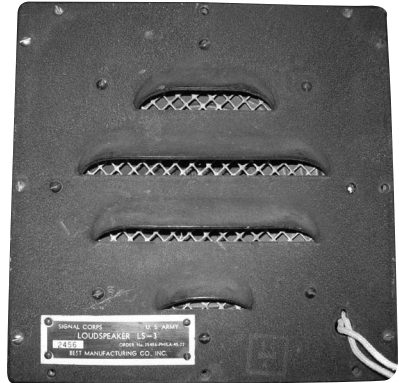


Photo Review



US Navy Model "RCH" – CZC-46209. Communications receiver made by E.H. Scott for the US Navy. Robert Rule, Augusta, ME.

US Army Signal Corps LS-3 Loud Speaker – Manufactured by Best Manufacturing Company for the US Army. Pat Timothy, Port Washington, NY.



US Navy Model CRV-46148 Communications Receiver – Made by RCA for the US Navy. Covers 4.0 Mhz to 27 Mhz. Robert Vogel, Deerfield, FL.

E.H. Scott SLRM Marine Radio – Audio produced by 2 25L6 tubes. Low radiation receiver. Steve Tessler, Detroit, MI.



Photo Review



Westinghouse Aeriola Sr. 1-tube receiver of 1921. Although the “Westinghouse” name is on the set, it was sold through the RCA marketing division. The first Aeriola had a wooden panel with silvered dials. This later version has an all-Bakelite panel. Dave Crocker - Mashpee, MA

Day-Fan Model OEM-7 four-tube receiver of 1924. It has a gold, silk-screened Balelite panel. Dave Crocker, Mashpee, MA



FADA (Frank Angelo D’Andrea), Model 175 – A five-tube receiver of 1925. FADA was one of the first radio manufacturers to incorporate the Hazeltine Neutrodyne circuit in their radios. FADA lasted well into the 1950’s with radio and Television products. Dave Crocker, Mashpee, MA.

CLASSIFIED ADVERTISEMENTS



FOR SALE: Rare Crosley Model VI two-tube receiver of 1923. It's all there and in fine shape. Solid box, clean complete chassis, original tag and two good Type 01-A tubes. Even has all the binding post caps (usually missing). \$220. Dave Crocker, 35 Santuit Pond Rd., #4B, Mashpee, MA, 02649. Tel. (508) 477-1578, before 9 p.m. EST please, Thanx.

FOR SALE: From the Terrey Collection. See full page ad in this issue. Marconi of America Magnetic Detector and Type CM-294A Receiver; RCA 106D (factory conversion from 106C); Mignon RLC5; Conn. Tel. & Elect. Co. DR-6 Sodian Receiver with (2) D-11-1 Amplifiers; Western Electric 3-B Receiver, 4-C Receiver, 4-D Receiver, 2-A Tuning Unit, 14-A Amplifier, 20-A Filter. John Terrey, Old Tech – Book & Things, PO Box 803, Carlisle, MA 01741. (978) 369-9770. E-mail: jvt@oldtech.com.

FOR SALE: Splitdorf model D battery radio horn speaker – good continuity. \$55 plus postage. Robert Burich, PO Box 4157, Pittsburgh, PA 15202. (412) 732-9647.

FORSALE: Dynamotors: ARC 14482, Type DMX310, 28 VDC , 2 EA DY-86/ARN-30 1 EA D-10A (28v), Type OS-200, 14 VDC, Type DM21B, 14 VDC, Radio Receiver, R19/R-508/ARC aircraft radio with attached DMX310 dynamotor, Radio receiver type BC-348-O, without modifications. John Zima, 1360 Reed Rd., Churchville, NY 14428. (585) 293-3023. E-mail: jfz_rhy@yahoo.com.



FOR SALE: Exact replica of the Crosley PUP box. Graphics taken from my original. Hard to mistake it for the real thing! All four sides are depicted. Real nice addition to your collection. \$42. plus \$9 shipping. Dave Crocker, 35 Santuit Pond Rd., #4B, Mashpee, MA 02649. Tel: (508) 477-1578, before 9 p.m. EST please. Thanx.

FOR SALE: Early Palm III, hand held, two in boxes. Make offer. Also CB equipment, mobile, base station, etc. One mobile NIB. Howard Felder, 7517 Granada Dr., Bethesda, MD 20817. (301) 320-3028.

FOR SALE: Hammarlund SP-600 receiver-\$150; National NC 109 receiver- \$175; Hickok 800A tube tester- \$135 needs shorts wafer switch; Knight R-100A receiver \$200; Old QST magazines free. Carter Elliott, 1460 Pinedale Rd., Charlottesville, VA 22901. (434) 566-8767. E-mail: celiott14@aol.com.

FOR SALE: Idler wheels for all brands of record players. Tape recorder wheels and rollers too. Wide selection. Can custom rebuild less popular wheels. Have motor mounts for popular models. Large needle selection. Changer power cords with Amplock or Molex plugs. Many more phono / tape recorder parts. Gary Stork, 37530 E. Meadowhill, Northville, MI 48167. (248) 478 0990. E-mail info@thevoiceofmusic.com. Web site: www.thevoiceofmusic.com.

FOR SALE: Wholesale Lots available, Huge Quantities, Tubes, Picture Tubes, Needles, Cartridges, Zenith Parts, Semiconductors, Data, Radios, Phonographs, Televisions and Test Equipment. Collector, Restorer and Volume Pricing. Ray Seppler, SunRad, 8 East Main St., Sodus, NY 14551. (315) 483-8451, FAX (315) 483-4873. E-mail: sunshine.radio@sunrad.com. Web site: <http://radios.sunrad.com>.



FOR SALE: RCA/Nipper Maintenance mats, new old stock (probably 1980s); red vinyl, black cloth backing, 51 by 31 inches, 1.3 lbs. Two Nipper (dog and Victrola) logos with words "RCA Replacement Parts" in white at top and bottom. Mats were intended for use by technicians repairing electronics in your home. Each mat is mint, folded in its original stapled plastic bag, with an insert printed "RCA Stock # 1F8084". Fine for display table coverings. \$43, or two for \$80, postpaid in U.S. Email or phone if desire more information. Alan Diamant, 108 Redwood Dr., Madison, AL 35758. (256) 325-4600. E-mail: amdiamant@aol.com.

FOR SALE: Tubes used tested USA at \$1.50 each: 6SA7, 6SK7, 6SJ7, 12SA7, 12SQ7, 12SK7, 6BA6, 6BE6, 6AT6, 6AV6, 12BA6, 12BE6, 12AV6. Rectifiers & audio at \$3 each: 50L6, 35Z5, 35L6, 6AQ5, 6K6, 6W6, 6J5, 6C5, 6X4, 12X4. Premium types at \$7 each: 6CA4, 12AX7, 80, 6WE6, 6JS6, 6LB6, 6BQ5. Call for others. James Lopaz, 5467 S. 975 E., Ogden, UT 84405. (602) 373-4002.

FOR SALE: TUBES, thousands of radio, TV, audio, and ham types. Low prices! New and like new, 30 day warranty. Accept check, money order, or PayPal. Send SASE for catalog. Please call, write, or visit. Da-

mon Vandehey, 2095 SE Currin La., Hillsboro, OR 97123. (503) 459-1777. E-mail: atstubes@gmail.com. www.antiquetube-supply.webs.com.

FOR SALE: American Bosch console radio Model 58, 1930's serial no. 47967 44"Hx28"Wx13"D, \$40 obo, see pictures at, www.buyat.20m.com. Alex Taranko, 3515 Old Yorktown Rd., Yorktown Heights NY 10598. (914) 962-2350. E-mail: sci983art@aol.com.

FOR SALE: Books on Wireless & Pre 1920 Radio, Medical Electricity and X-Rays. Also books by and about Nikola Tesla and Tesla Coils. To see our listings, visit our web page www.beqbooks.com Direct orders get 10% discount. BEQUAERT OLD BOOKS, PO Box 775, Fitzwilliam, NH 03447. (603) 585-3448. E-mail: info@beqbooks.com.

FOR SALE: FSOT, CMPD, FOR SALE OR TRADE, CONSIDER MERE PAPER DOLLARS!: Heathkit DX 100 super clean original outside and inside; Heath Apache also very nice; BC 375 E working with several tuning units and PE 73 Dynamotor/cables. GRC 9, very good, working with DY 88, cables, and T17 mic. All you need is a ticket. Hammarlund SP 600 in case, very nice, works fine; HRO RAS Navy version, several coils and power supply; BC 654, nice all original and working, also have new/old stock PE 103 Dynamotor; Collins 323 V nice, working; BC 669 transceiver with original power supply; Drake TR7 with PS 7, very nice and working; HRO 50T1, rackmount, nice working, have several coil sets; HRO 50T1 cabinet model, has been recapped, was working fine, now need to find error in recapping! Several coils available. HRO Senior rackmount power supply, several coils; Webcor 210-1-C collectible early Webcor wire. ALWAYS BUYING: Early and interesting wire and tape recorders, disc cutters, broadcast and recording mics, tube pre-amps, compressors, early hi-fi, cash or trade for any of above. Prefer pick-up on heavy items, but can ship. Ward Kremer, K14JHA, 57262 Poppy Rd., South Bend, IN 46619. (574) 204-2877. E-mail: witzend99@comcast.net, website: <http://www.radioattic.com/kremer>

FOR SALE: Federal 8, 9, 55, 56 reproduction cabinets. For details, contact John Terry, Old Tech – Books & Things, PO Box 803, Carlisle, MA 01741. E-mail: jvt@old-tech.com.

FOR SALE: See items at <http://antiqueraudioexchange.com/> sold by richsequip, most listed under TEST EQUIPMENT with photos & detailed descriptions. Many seldom offered for sale & going back as far as 1936. Richard Flaws, 212 Mondovi Dr., Oswego, IL 60543. (630) 554-9207 (Before 9pm CT). E-mail: flaws2@att.net



WANTED: (Photo above) RCA 143 tombstone. Mark Murphy, 931 Village Blvd., Ste. 905-381, West Palm Beach, FL 33409; (561) 801-1478; E-mail: markmmurphy@att.net. **WANTED:** Dial scale glass for Philco model 42-321. It is 1 " x 7 ". Has 2 band scales. Dean Rein, 4307 Hwy 52, Wausau, WI 54403. (715) 842-8354. E-mail: stoncantiq@aol.com.

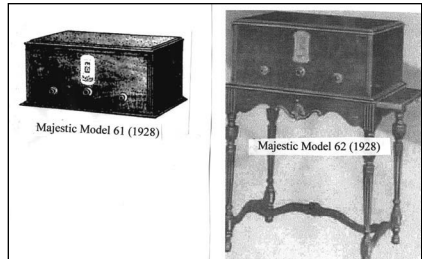
WANTED: Power transformer (95-521) and transformer specifications for Zenith Chassis #5528, model 5R312. Terry Rohler, 33 Woolfolk Dr., Mineral, VA 23117. (540) 872-1895. E-mail: lrohler@msn.com.

WANTED: Philco model 42-321 dial scale glass. It measures 1 " x 7 " and has 2 band scales. Dean Rein, 4307 Hwy 52, Wausau, WI 54403. (715) 842-8354. E-mail: stoncantiq@aol.com.

WANTED: Radio boys book The Ocean Wireless Boys on war swept seas by Capt Wilbur Lawton year 1917. Must have a decent dust jacket. Tom Pamula, 2017 Crestview Dr., Erie, PA 16509. E-mail: radio-kid1@verizon.net.

WANTED: Wanted, Hickok adapter 1704 for TV-7 tester, also still need knob for Bendix 526C radio. Buzz Miller, 725 Mt. Rock Rd., Carlisle, PA 17015. (717) 385-0429. E-mail: buzz2@embarqmail.com.

WANTED: Do you have so many vacuum tubes that you don't know what to do with them? Before you trash those tubes call me and I'll try to find a home for them. Jeff Arndt, 4021 S. Parker Way, De Pere, WI 54115. (920) 323-6789.



WANTED: Grigsby Grunow (Majestic) AM radio models 61 & 62 (1928). Reward: \$100 finder's fee, paid at time of sale, to person finding either of these radios. These radios may be in any condition, working or not working, for a refurbishment project. Contact Richard Blum with your "find" at PO Box 2626, Palos Verdes Peninsula, CA 90274. E-mail: richieraider@juno.com.

WANTED: Record player new old stock cartridges. Bulk purchase of Astatic, EV/Game, Pfanstiehl or what have you a quantity of. Always buying Voice of Music Factory Service parts in the yellow envelopes and boxes. Gary Stork, 37530 E. Meadowhill, Northville, MI 48167. (248) 478 0990. E-mail: info@thevoiceofmusic.com. Web site: www.thevoicofmusic.com.

WANTED: Base/stand assembly for RCA Radiola 103 tapestry loudspeaker. Must be complete and in good condition. Bruce Baxley, 15 Barnett Dr., Savannah, GA 31406. (912) 352-2362. E-mail: b.baxley401@comcast.net.

WANTED: Information/schematic/Technical data for Keller-Fuller, Radiette with 6C6, 6D6, 43, 25Z5 tubes. Terry Rohler, 33 Woolfolk Dr., Mineral, VA 23117. (540) 872-1895. E-mail: lrohler@msn.com.

WANTED: 1938 Grunow Teledial Parts Chassis with good Dial Assembly. Model 589, 623, 663, or 1067; all have identical dial assemblies. I need one with good station preset buttons. Gordon Ormsby, 2298 SE Kiger Island Dr., Corvallis, OR 97333. (541) 753-6398. E-mail: gormsby0306@gmail.com.

WANTED: Video disc movies for the RCA Selectavision CED player SJJ100. Gregory Parker, 1005 Sulphur Springs Rd., Irving, NY 14081. (716) 549-7223. E-mail: Gregorparke@earthlink.net.



WANTED: Offering \$500-\$1500 for the PICTURED Admiral or Hoffman Solar transistor radios. Admirals MUST include the Sun-Pak (but also paying well for the Sun-Pak or custom carrying case without radio). Color, cosmetic condition and playability will determine value. THANKS! Bill Burkett, PO Box 2488, Sun City AZ 85372. (623) 974-4535. E-Mail: Bill.Burkett@cox.net.

WANTED: Two small trim metal pieces located around the sides of the record deposit bin: used on Victors first generation automatic record changer models 10-50, 10-51, 10-70, and 9-55. David Franklin, 2513 E Verde Ln., Phoenix, AZ 85016. (602) 748-5787. E-mail: davidphotofinish@gmail.com

WANTED: I am the home for your vacuum tubes. E-mail your list or call to receive fair price. Joe Johnson, N1873 Greenville Dr., Greenville, WI 54942. (920) 757-9827. E-mail: jjohnson74@new.rr.com.

WANTED: Hickok Traceometer Model #156. Restorable or in good condition. Will pay your reasonable price. David Boyle,

1058 Colt Cir., Castle Rock, CO 80109. (303) 681-3258. E-mail: djboylesr@msn.com.

WANTED: RCA C6-11 console, need not work but must be in overall good condition. Bill Bickers, 259 Alabama St., St. Simons Island, GA 31522. (912) 634-5800. E-mail: jukebox@technonet.com.

WANTED: Power transformer # 32-8052 for Philco radio model 40-180. Robert Hardtke, 203 SE 3rd St., Lamoure, ND 58458. (701) 883-5878. E-mail: rhardtke@drtel.net.

WANTED: Looking to buy shortwave/ham/cb radio collections, any condition in NY tri-state area, cash paid ASAP. Juan Remus KC2ZTE, 2 Springbriar Ln., Kings Park, NY 11754. (631) 697-5850. E-mail: stocpro47@yahoo.com

WANTED: Stereo/Hifi/Commercial Tube Gear, Amps/Speakers/Parts/etc, Guitars, Guitar amps/Pedals/Parts, Tube Testers and Audio Tubes. Sonny Goldson, 520 Pocahontas Dr., Fort Walton Beach, FL 32547. (850) 314-0321. E-mail: sonnysound@aol.com.

FOR SALE/TRADE: Classic Hi-Fi era speakers, one ea.: Bozak 302A, Electro Voice "Marquis", Electro Voice "Klipch" style corner horn with brass bars on grille, all loaded with 12' drivers / tweeters sounding great - possible radio show delivery. See my previous ads for many great consoles still available. **WANTED:** Airrite/Kadette Deskset and/or pen & clock. C.R. Nevins Museum of Radio, Ken Nevins, 406 Jipson St., Blissfield, MI 49228. (517) 486-3019 evenings. E-mail: ken@kennevins.com.

WANTED: Vintage Movie Posters, Lobby Cards, still photos, Live Music Posters. All Sizes, Any Condition. Will buy entire collections! Ralph DeLuca, 157 Park Ave., Madison, NJ 07940. (800) 392-4050. E-mail: Ralph@ralphdeluca.com.

SERVICES: Repairs to vintage tube equipment including home receivers, phonographs, and auto radios. South Bay Radio, 7187 Lakeshore Rd., Cicero, NY 13039. (315) 699-7341.

SERVICES: All American table radio restoration specials: 5-tube \$49.99; 6-tube \$59.99. Other flat rate restorations for larger radios, car radios & TVs. Send E-mail, write, call, or visit my web sites for details. Dave's Antique Radio and TV Restorations, PO Box 285, Liverpool, NY 13088. E-mail: dave2@dreamscape.com or dave2@tubesandtransistorsandmore.com. Web sites: www.dreamscape.com/dave2/daves.htm or www.tubesandtransistorsandmore.com. (315) 944-0265.

SERVICES: Logan's TV & Radio Repair. Logan's has over 3,000 rare radio tubes for sale. We also repair old radios, through our repair and ship service. Please contact: George for further details at Logan's, Rear 526 Mt. Pleasant St., Greensburg, PA 15601. (724) 836-2163 or (724) 837-5580.

SERVICES: Since 1987 Sound Remedy has specialized in reconing vintage loudspeakers used in antique radios, automobiles, jukeboxes and musical instruments as well as stereo and high-power Pro speakers. Our repair work is meticulous and guaranteed. Contact Sound Remedy, 331 Virginia Ave, Collingswood, NJ 08108. (856) 869-0238. E-mail: soundremedy@aol.com.

SERVICES: Antique Radio of Iowa & vintage furniture restorations. All bands electronic chassis repair. Sorry, no foreign units or conversions. Speaker service wood & veneer cabinet restoration. Plasti/bakelite repair and painting. Vintage auto radio repair. Tybe hybrid, all transistor, 8 track, 1930s to 1960s. Check out my eBay Store: iowacollectablesusa. PayPal and cashiers check welcome. 7 days a week. Don Nordboe, 3131 Avenue A, Council Bluffs, IA 51501. (712) 322-2255. E-mail: dnordboe@aol.com. Web: www.antiqueradioof-iowa.com

SERVICES: Repair of old radio, car radio, audio, stereo. Free estimate, reasonable cost, #1 Google "Vintage Hi-Fi repair". Mike Urban, 37 Elm St., Windsor, CT

06095. (203) 877-2409. Web: www.urban-antiqueradio.com

SERVICES: Utah Reconing your full service speaker reconing and repair shop. Fast turn around specializing in antique radio speakers as well as a full service reconer. 22 years experience, reasonable prices, quick turn around. Matt Shelton, Utah Reconing, 7120 Camelot Way, West Jordan, UT 84084. (801) 694-0166. E-mail: redmatt@juno.com.

SERVICES: Northern Arizona sales, service, and parts for tube radios, amplifiers, auto radios. Vintage Radio, 440 W. Palomino Dr., Chino Valley, AZ 86323 next to our Radio Shack store. (928) 636-5140. E-mail: info@azvintageradio.com. www.azvintageradio.com.

SERVICES: Tube radio and some instrument repairs for the Rocky Mtn. region.

FOR SALE: Selection of repaired, refurbished, and calibrated radio and TV test equipment. Includes RCA, EICO, Heathkit, PACO, etc. David Boyle 1058 Colt Cir. Castle Rock, CO, 80109, (303) 681-3258, djboylesr@msn.com

SERVICES: Do you need your test equipment repaired or calibrated? I can help. Very reasonable rates. Rod Galloway, 2961 SE 152nd Ave., Morriston, FL 32668. (352) 528-9499. E-mail: rodgall@wildblue.net.

*Attention Subscribers:
You can access a color
version of articles on the
A.R.C. website at
www.antiqueradio.com.*



COMING RADIO EVENTS



NEW JERSEY – May 2

New Jersey Antique Radio Club
Wall, NJ – InfoAge Science Bldg. L-9032A
2201 Marconi Rd. - 7:30 pm
Info: Marv Beeferman (609) 693-9430
Rich Lee (914) 589-3751
E-mail: radiatorich@prodigy.net

Join us on our live webcast: www.njarc.org

INDIANA – May 2-3

Indiana Historical Radio Society
IHRS Spring Meet
Quality Inn Suites
Kokomo, IN
Info: Fred Prohl (812) 988-1761 Dr. Ed
Taylor (317) 638-1641
Web Site: www.indianahistoricalradio.org

CALIFORNIA – May 3

California Historical Radio Society
Swap Meet – 9am to 3pm
College of San Mateo
1700 W. Hillsdale Blvd., San Mateo, CA
Info: www.californiahistoricalradio.com

IOWA – May 3

Iowa Antique Radio Club
Annual Antique Radio Auction
Hawkeye Downs – 10am
Cedar Rapids, IA
Info: Dwight Baker (515) 965-0999
www.iowa-antique-radio-club.com

MICHIGAN – May 3

Michigan Antique Radio Club
MARC Spring Meet – 9:00am to 3:00pm
Midland, MI – Valley Plaza Resort
5221 Bay City Road
Info: Mark Oppat (734) 207-2346
Web Site: www.michiganantiqueradio.org

WASHINGTON – May 3

Radio Enthusiasts of Puget Sound
Seattle, WA – Norse Home – 2pm to 4pm
Info: www.repsonline.org

NEW YORK – May 4

Greater New York Vintage Wireless
Association
Swap Meet & Meeting
Seaford, NY Train Station Parking Lot
7 am - 11 am Info: Jon Kummer
jonk@nyantiqueradio.org
Jim Koehler - (516) 623-0035
Rich Lee - (914) 589-3751
Web site: www.nyantiqueradio.org

PENNSYLVANIA – May 9-10

Delaware Valley Historic Radio Club
Kutztown XXX Radio Meet

Kutztown, PA
Info: www.dvhrc.info

OKLAHOMA – May 10

Oklahoma Vintage Radio Collectors
Meeting
Oklahoma Station BBQ
Oklahoma City, OK
Dinner 6:00pm, Meeting 7:00pm
Info: Jim Collings - (405) 755-4139
jrcradio@cox.net
Web Site: www.okvrc.org

OREGON – May 10

Northwest Vintage Radio Society
Meeting & Tailgate Swap
Oregon City, OR - Abernethy Grange Hall
15745 S. Harley Ave. - 7:30 am - Meeting:
10 am
Info: www.nwvrs.org

NEW MEXICO – May 11

New Mexico Radio Collectors Club Meet
Albuquerque, NM - Kaseman Presb.
Hospital
8300 Constitution Ave. (W. of Wyoming)
Info: www.newmexicoradiocollectorsclub.com

MISSOURI – May 13

Antique Radio Coll. & Hist. of Greater St.
Louis Meeting
Kirkwood, MO - Kirkwood Comm. Ctr
111 S. Geyer Rd., Room 201-A
7:30 pm Meeting
Info: Joe Tauser - (314) 616-0745
joe@jtauser.com
Web Site: www.archradioclub.com

PENNSYLVANIA – May 13

Delaware Valley Historic Radio Club
Monthly Meeting 7:30pm
Telford Community Center, Telford, PA
Info: www.dvhrc.info

OHIO – May 14

Cincinnati Antique Radio Society
Club Meeting – 7:30pm
Fairfield Pavillion, Rte 4, Fairfield, OH
Info: Bob Sands (513) 858-1755
E-mail: oltubes@roadrunner.com
Web Site: www.cincinnati-antique-radio.org

OKLAHOMA – May 15

Heartland Antique Radio Association
Topic: Philco
Hardesty Library – 6:30pm
Tulsa, OK
Info: www.hlara.org

NEW YORK – May 16

Hudson Valley Antique Radio &
Phonograph Society
Club Meeting
Episcopal Church of Suffern
65 Washington Street 7:30pm
Info: <https://sites.google.com/site/nyharps>. Dale Cranston (845) 357-1615

MINNESOTA – May 16 - 17

Northland Antique Radio Club
Radio Daze 2014
Info: www.northlandantiqueradioclub.com

OHIO – May 16-18

Early Television Convention
Hilliard, OH
Info: www.earlytelevision.org

NEW YORK – May 17

Long Island Radio & TV Historical Society
Club Meeting – 10am
Sayville, NY
Info: www.lirtvhs.org

OHIO – May 17

Estes Radio Auction
Burbank, OH
Info: www.estesauctions.com

TENNESSEE – May 17

Music City Vintage Radio Club
Monthly Meeting
Nashville, TN
Info: www.musiccityvintageradio.org

TEXAS – May 17

Texas Antique Radio Club Meeting
Kyle, TX - Railroad BBQ 9:30 am
Info: Ed Engelken - EdEngel@gvct.com
(830) 899-3864
Web Site: www.tarc.gvctwebospace.net

TEXAS – May 17

Vintage Radio & Phonograph Society
Meeting
Senter East Center – Swap Meet 8am to
12noon
Irving, TX
Info: (817) 292-7435
Web Site: www.vrps.org

COLORADO – May 18

Colorado Radio Collectors Meeting –
1pm
Bemis Public Library, Littonton, CO
Info: David Boyle - (303) 681-3258
djboylesr@msn.com
Web Site: www.radioace.com

MARYLAND – May 18

Mid-Atlantic Antique Radio Club Meeting
Davidsonville, MD
Davidsonville Family Recreational Center
Tailgating: 11:30 - Meeting: 1:30 pm
Info: Web Site: www.maarc.org

WASHINGTON – May 18

Puget Sound Antique Radio Association
Cedar Valley Grange – 12noon
20526 52nd Ave. N., Lynnwood
Info: Lynda Glaspey (425) 478-3643
<http://www.eskimo.com/~lhagen/psara>

FLORIDA – May 19

Jacksonville Antique Radio Society
Monthly Meeting - 7:30pm
Countryside Village Clubhouse, 19060
Beach Blvd.
Info: Sean Olin - (904) 386-8332
Web Site: www.jarsradioclub.com

MISSOURI – May 19

Antique Radio Coll. & Hist. of Greater St.
Louis Meeting
Spring Picnic/Swap Meet
Manchester, MO – Schroeder Park –
8am to 1pm
Info: Joe Tauser - (314) 616-0745
joe@jtauser.com
Web Site: www.archradioclub.com

MISSOURI – May 24

Mid-America Antique Radio Club
Auction – 10am
Hickman Mills Church
Kansas City, MO
Info: Claude Chafin 816-786-2313
Web Site: <https://sites.google.com/site/midamericantiqueradioclub>

TEXAS – May 24

Houston Vintage Radio Association
Annual Swap Meet
Bayland Park Community Center
Info: Bill Werzner (713) 721-2242
E-mail: werz1943@gmail.com
Web Site: www.hvra.org

NEW YORK – May 25

Antique Radio Club of Schenectady
St. Roses College, Madison Ave., Albany,
NY – 12Noon
Info: Louis DeGonzague
(518) 391-9239
E-mail: zenith6@verizon.net Web Site:
<http://arcsweb.webng.com>

ALABAMA – May 26

Alabama Historical Radio Society
Meeting
Birmingham, AL – Alabama Power Bldg.
1801 Abraham Woods Blvd. – 7:00 pm
Info: Dee Haynes – (205) 841-4630
www.alabamahistoricalradiosociety.org

VIRGINIA – May 27

Tidewater Antique Radio & Phonograph
Assoc. (TARPA)

Club Meeting – 7pm

Norfolk, VA – Mary Pretlow Library,
Ocean View
Info: Barry Callis (757) 427-9667
E-mail: betty3689@aol.com

PENNSYLVANIA – May 31

Pittsburgh Antique Radio Society
Club Meeting
Vintage Portable TV's
Brentwood Presbyterian Church
3725 Brownsville Rd., Brentwood, PA
Info: Chris Wells (724) 942-1113, Regis
Flaherty (724) 969-0643
Web site: www.pittantiqueradios.org

NEW YORK – June 1

Greater New York Vintage Wireless
Association
Swap Meet & Meeting
Seaford, NY Train Station Parking Lot
7 am - 11 am Info: Jim Koehler
(516) 623-0035
Rich Lee - (914) 589-3751
Web site: www.nyantiqueradio.org

WISCONSIN – June 1

Wisconsin Antique Radio Club
Swap Meet 8:00am to 11:00am
The Terminal
5917 S. Howell Ave, Milwaukee, WI
Info: Greg Hunolt (920) 893-0422
E-mail: ghunolt@excel.net
Web Site: www.warci.org

CALIFORNIA – June 7

California Historical Radio Society
Swap Meet – 9am to 3pm
Info: www.californiahistoricalradio.com

CONNECTICUT – June 7

Vintage Radio & Comm. Museum of
Connecticut
Outdoor Spring Swap Meet – 8:00am
115 Pierson Ln., Windsor, CT
Info: www.vrcmct.org

WASHINGTON – June 7

Radio Enthusiasts of Puget Sound
Seattle, WA – Norse Home – 2pm to 4pm
Info: www.repsonline.org

NEW MEXICO – June 8

New Mexico Radio Collectors Club Meet
Albuquerque, NM – Kaseman Presb.
Hospital
8300 Constitution Ave. (W. of Wyoming)
Info: www.newmexicoradiocollectorsclub.com

WASHINGTON – June 8

Puget Sound Antique Radio Association
Cedar Valley Grange – 12noon
20526 52nd Ave. N., Lynnwood
Info: Lynda Glaspey (425) 478-3643
<http://www.eskimo.com/~lhagen/psara>

MISSOURI – June 10

Antique Radio Coll. & Hist. of Greater St.

Louis Meeting

Kirkwood, MO – Kirkwood Comm. Ctr
111 S. Geyer Rd., Room 201-A
7:30 pm Meeting
Info: Joe Tauser - (314) 616-0745
joe@jtauser.com
Web Site: www.archradioclub.com

PENNSYLVANIA – June 10

Delaware Valley Historic Radio Club
Monthly Meeting 7:30pm
Telford Community Center, Telford, PA
Info: www.dvhrc.info

NEW JERSEY – June 13

New Jersey Antique Radio Club
Princeton, NJ – Bowen Hall
70 Prospect Ave. - 7:30 pm
Info: Marv Beeferman (609) 693-9430
Rich Lee (914) 589-3751
E-mail: radiorich@prodigy.net
Join us on our live webcast: www.njarc.org

OKLAHOMA – June 14

Oklahoma Vintage Radio Collectors
Meeting
Oklahoma Station BBQ
Oklahoma City, OK
Dinner 6:00pm, Meeting 7:00pm
Info: Jim Collings - (405) 755-4139
jrcradio@cox.net
Web Site: www.okvrc.org

OREGON – June 14

Northwest Vintage Radio Society
Meeting & Tailgate Swap
Oregon City, OR – Abernethy Grange Hall
15745 S. Harley Ave. - 7:30 am -
Meeting: 10 am
Info: www.nwvrs.org

ILLINOIS – June 15

Antique Radio Club of Illinois
Outdoor Swap Meet – 7am
Combined meet with 6 meter club of
Chicago
DuPage County Fairgrounds, Wheaton, IL
Info: www.antique-radios.org

FLORIDA – June 16

Jacksonville Antique Radio Society
Monthly Meeting - 7:30pm
Countryside Village Clubhouse, 19060
Beach Blvd.
Info: Sean Olin – (904) 386-8332
Web Site: www.jarsradioclub.com

OHIO – June 18

Ohio Antique Radio Association
Club Meeting
Columbus, OH
Info: www.coara.org

NEW YORK – June 20

Hudson Valley Antique Radio &
Phonograph Society
Club Meeting
Episcopal Church of Suffern

65 Washington Street 7:30pm
Info: <https://sites.google.com/site/nyharps>. Dale Cranston (845) 357-1615

CALIFORNIA – June 21

Southern California Antique Radio Society

Swap Meet

J.L. Fisher, 1000 W. Isabel St., Burbank, CA

Info: Jim Ryan (714)-263-5547

Web Site: www.antiqueradios.org

NEW JERSEY – June 21

New Jersey Antique Radio Club
Wall, NJ – InfoAge Science Bldg. L-9032A

2201 Marconi Rd. - 7:30 pm

Info: Marv Beeferman (609) 693-9430

Rich Lee (914) 589-3751

E-mail: radiatorich@prodigy.net

Join us on our live webcast: www.njarc.org

NEW YORK – June 21

Long Island Radio & TV Historical Society

Club Meeting – 10am, Sayville, NY

Info: www.lirtvhs.org

OHIO – June 21

Cincinnati Antique Radio Club

Annual Radiorama Swap Meet, Blue Ash, OH

Info: Bob Sands (513) 858-1755

E-mail: olubes@roadrunner.com

Web Site: www.cincinnati-antique-radio.org

TEXAS – June 21

Vintage Radio & Phonograph Society Meeting

Garden and Arts Building – 1pm to 5pm, Irving, TX

Info: (817) 292-7435 – Web Site:

www.vrps.org

NEW YORK – June 22

Antique Radio Club of Schenectady

St. Roses College, Madison Ave., Albany, NY – 12Noon

Info: Louis DeGonzague (518)

391-9239

E-mail: zenith6@verizon.net Web Site:

<http://arcsweb.webng.com>

TEXAS – June 22

Texas Antique Radio Club Meeting

Schertz, TX – VFW Hall – 2pm

Info: Ed Engelken - EdEngel@gvtc.com

(830) 899-3864

Web Site: www.tarc.gvtcwebospace.net

ALABAMA – June 23

Alabama Historical Radio Society Meeting

Birmingham, AL – Alabama Power

Bldg.

1801 Abraham Woods Blvd. – 7:00

pm

Info: Dee Haynes – (205) 841-4630

www.alabamahistoricalradiosociety.org

VIRGINIA – June 24

Tidewater Antique Radio &

Phonograph Assoc. (TARPA)

Club Meeting – 7pm

Norfolk, VA – Mary Pretlow Library, Ocean View

Info: Barry Callis (757) 427-9667

E-mail: betty3689@aol.com

MARYLAND – June 26-28

Mid-Atlantic Antique Radio Club

RadioActivity 2014

Timonium, MD

Holiday Inn

Info: www.maarc.org

OKLAHOMA – June 28

Heartland Antique Radio Association

Summer Sizzler

Asbury United Methodist Church

Tulsa, OK

Info: www.hlara.org

TENNESSEE – June 29

Music City Vintage Radio Club

Monthly Meeting

Nashville, TN

Info: www.musiccityvintageradio.org

WASHINGTON – July 5

Radio Enthusiasts of Puget Sound

Seattle, WA – Norse Home – 2pm

to 4pm

Info: www.repsonline.org

NEW YORK – July 6

Greater New York Vintage Wireless

Association

Swap Meet & Meeting

Seaford, NY Train Station Parking Lot

7 am - 11 am Info: Jim Koehler -

(516) 623-0035

Rich Lee - (914) 589-3751

Web site: www.nyantiqueradio.org

MISSOURI – July 8

Antique Radio Coll. & Hist. of Greater

St. Louis Meeting

Kirkwood, MO - Kirkwood Comm. Ctr

111 S. Geyer Rd., Room 201-A

7:30 pm Meeting

Info: Joe Tauser - (314) 616-0745

joe@jtouser.com

Web Site: www.archradioclub.com

PENNSYLVANIA – July 8

Delaware Valley Historic Radio Club

Monthly Meeting 7:00pm

Telford Community Center, Telford, PA

Info: www.dvhrc.info

OHIO – July 9

Cincinnati Antique Radio Society

Club Meeting – 7:30pm

Fairfield Pavillion, Rte 4, Fairfield, OH

Info: Bob Sands (513) 858-1755

E-mail: olubes@roadrunner.com

Web Site: www.cincinnati-antique-radio.org

MICHIGAN – July 10-12

Michigan Antique Radio Club

Extravaganza '14

Lansing, MI – Best Western Plus

6820 S. Cedar Street

Info: Marv Oppat (734) 207-2346

Web Site: www.michiganantiqueradio.org

NEW JERSEY – July 11

New Jersey Antique Radio Club

Princeton, NJ – Bowen Hall

70 Prospect Ave. - 7:30 pm

Info: Marv Beeferman

(609) 693-9430

Rich Lee (914) 589-3751

E-mail: radiatorich@prodigy.net

Join us on our live webcast: www.njarc.org

OKLAHOMA – July 12

Oklahoma Vintage Radio Collectors

Meeting

Oklahoma Station BBQ

Oklahoma City, OK

Dinner 6:00pm, Meeting 7:00pm

Info: Jim Collings - (405) 755-4139

jrcradio@cox.net

Web Site: www.okvrc.org

OREGON – July 12

Northwest Vintage Radio Society

Meeting & Tailgate Swap

Oregon City, OR - Abernethy Grange

Hall

15745 S. Harley Ave. - 7:30 am -

Meeting: 10 am

Info: www.nwvrs.org

COLORADO – July 13

Colorado Radio Collectors Meeting, 1pm

Bemis Public Library

Littonton, CO

Info: David Boyle - (303) 681-3258

djboylesr@msn.com

Web Site: www.radioace.com

NEW MEXICO – July 13

New Mexico Radio Collectors Club

Meet

Albuquerque, NM - Kaseman Presb.

Hospital

8300 Constitution Ave. (W. of

Wyoming)

Info: www.newmexicoradiocollectorsclub.com

OKLAHOMA – July 17

Heartland Antique Radio Association

Topic:

Hardesty Library – 6:30pm
Tulsa, OK

Info: www.hlara.org

NEW YORK – July 18

Hudson Valley Antique Radio &
Phonograph Society
Club Meeting

Episcopal Church of Suffern

65 Washington Street 7:30pm

Info: <https://sites.google.com/site/nyharps>. Dale Cranston (845) 357-1615

WEST VIRGINIA – July 18-19

Museum of Radio & Technology
Summer Heat Traders Show & Auction

1640 Florence Ave., Huntington, WV
Info: 304-525-8890

Web Site: www.mrtwv.org

NEW YORK – July 19

Long Island Radio & TV Historical
Society

Club Meeting – 10am

Sayville, NY

Info: www.lirtvhs.org

TENNESSEE – July 19

Music City Vintage Radio Club

Summer Swap Meet

Nashville, TN

Info: www.musiccityvintageradio.org

TEXAS – July 19

Texas Antique Radio Club Meeting

Kyle, TX - Railroad BBQ 9:30 am

Info: Ed Engelken - EdEngel@gvtc.com (830) 899-3864

Web Site: www.tarc.gvtcwebspace.net

TEXAS – July 19

Vintage Radio & Phonograph Society
Meeting

Senter East Center – Repair Session

8am to 12noon

Irving, TX

Info: (817) 292-7435 – Web Site:
www.vrps.org

MARYLAND – July 20

Mid-Atlantic Antique Radio Club
Meeting

Davidsonville, MD

Davidsonville Family Recreational
Center

Tailgating: 11:30 - Meeting: 1:30 pm

Info: Web Site: www.maarc.org

WASHINGTON – July 20

Puget Sound Antique Radio
Association

Cedar Valley Grange – 12noon

20526 52nd Ave. N., Lynwood

Info: Lynda Glaspey (425) 478-3643
<http://www.eskimo.com/~hhagen/psara>

WISCONSIN – July 20

Wisconsin Antique Radio Club

Swap Meet 8:00am to 11:00am

The Terminal, Milwaukee, WI

Info: www.warci.org

FLORIDA – July 21

Jacksonville Antique Radio Society

Monthly Meeting - 7:30pm

Countryside Village Clubhouse, 19060
Beach Blvd.

Info: Sean Olin – (904) 386-8332

Web Site: www.jarsradioclub.com

VIRGINIA – July 22

Tidewater Antique Radio &

Phonograph Assoc. (TARPA)

Club Meeting – 7pm

Norfolk, VA – Mary Pretlow Library,
Ocean View

Info: Barry Callis (757) 427-9667

E-mail: betty3689@aol.com

CALIFORNIA – July 26

California Historical Radio Society

Radio Day by the Bay

Location: TBA

Info: www.californiahistoricalradio.com

NEW JERSEY – July 26

New Jersey Antique Radio Club

Wall, NJ – InfoAge Science Bldg.

L-9032A

2201 Marconi Rd. - 7:30 pm

Info: Marv Beeferman (609) 693-
9430

Rich Lee (914) 589-3751

E-mail: radiorich@prodigy.net

Join us on our live webcast: www.njarc.org

[njarc.org](http://www.njarc.org)

TENNESSEE – July 26

Music City Vintage Radio Club

Monthly Meeting

Nashville, TN

Info: www.musiccityvintageradio.org

MISSOURI – July 27

Mid-America Antique Radio Club

Auction – 10am

Leawood Park

Info: Claude Chafin 816-786-2313

Web Site: <https://sites.google.com/site/midamericaantiqueradioclub>

NEW YORK – July 27

Antique Radio Club of Schenectady

St. Roses College, Madison Ave.,

Albany, NY – 12Noon

Info: Louis DeGonzague (518)

391-9239

E-mail: zenith6@verizon.net Web Site:

<http://arcsweb.webng.com>

PENNSYLVANIA – July 27

Pittsburgh Antique Radio Society

Summer Picnic – 11am

Contest: Walkie Talkies

North Park Roosevelt Pavillion

Allison Park, PA

Info: Chris Wells (724) 942-1113,

Regis Flaherty (724) 969-0643

Web site: www.pittantiqueradios.org

ALABAMA – July 28

Alabama Historical Radio Society

Meeting

Birmingham, AL – Alabama Power
Bldg.

1801 Abraham Woods Blvd. – 7:00 pm

Info: Dee Haynes – (205) 841-4630

www.alabamahistoricalradiosociety.org

ILLINOIS – July 31, August 1-2

Antique Radio Club of Illinois

RADIOFEST 2014

Willowbrook Holiday Inn

Info: www.antique-radios.org



CLUBS: Send antique radio club and meet information to A.R.C. for free listing here, as space permits. Sorry, we don't have room for hamfests. Always send a SASE when writing to clubs!

NATIONAL CLUBS

Antique Wireless Association (AWA). PO Box 421, Bloomfield, NY 14469. Pub: The AWA Journal, quarterly. Dues: \$35 (U.S.A) \$40 (elsewhere). National annual conference and regional meets. Museum. www.antiquewireless.org. AWA World Convention: <http://awamuseum.org/>

REGIONAL CLUBS

Alabama Historical Radio Society (AHRs). PO Box 131418, Birmingham, AL 35213. Pub: The Superflex, monthly. Dues: \$20. Meetings, Every Sat. morning and 4th Mon. evening each month but Dec., annual show/swap meet. Don Kresge Radio Museum, Lobby of the Alabama Power Bldg., 600 North 18th Street, Birmingham, AL 35203. Contact Dee Haynes (205) 841-4630. www.alabamahistoricalradiosociety.org.

Antique Radio Club of Illinois (ARCI). PO Box 1139, LaGrange Park, IL 60526. Art Bilski (630) 739-1060. Pubs: ARCI News, monthly and ARCI Update, periodically. Dues \$20. Annual August Radiofest and bimonthly swap meets. www.antique-radios.org. clubinfo@antique-radios.org.

Antique Radio Club of Schenectady. Louis DeGonzague, 15 Gail Ln., Latham, NY 12110. (518) 391-9239. E-mail: zenith6@verizon.net. Dues: \$3. Meets the 4th Sunday of each month at St. Roses College, Madison Ave., Albany, NY at 12noon. Web Site: <http://arcsweb.webng.com>

Antique Radio Collectors & Historians (ARCH) of Greater St. Louis. Joe Tauser, jtauser.com. Dues: \$15. Monthly newsletter and meetings, annual picnic/swap meet. www.archradioclub.com.

Antique Radio Collectors Club of Ft. Smith, Arkansas (ARCC). Mark Schemel (479) 471-1052, 6525 S. Lakewood Dr., Van Buren, AR 72956. Dues: \$10. Meets first Thursday of month. E-mail: schemelbill@aol.com

Antique Radio Collectors of Ohio (ARCO). Karl Koogle, 2929 Hazelwood Ave., Dayton, OH 45419. E-mail: karlkrad@gmail.com.

Arizona Antique Radio Club (AZARC). 1080 E. Pecos Rd., Suite 18, PMB 105, Chandler, AZ 85225-2426. Pub: The Arizona Antique Radio Club News, quarterly. Dues: \$20. Meetings, swap meets, Arizona Radio Roundup. www.azantiqueradioclub.org

Buckeye Antique Radio and Phonograph Club (BARPC). Jon Jansma, 31051 Fox Hollow Dr., Pepper Pike, OH 44124. (216) 591-0121. Pub: Soundings, bimonthly. Dues: \$10.00. Monthly meetings in Akron, Spring and Fall auctions, April joint meeting with PARS. www.pittantiqueradios.org/barpc

California Historical Radio Society (CHRS). Bay Area Radio Museum (BARM) and the Society of Wireless Pioneers (SOWP). CHRS, PO Box 31659, San Francisco, CA 94131. CHRS Hotline: (415) 821-9800. Steve Kushman, President kushseal@flash.net. Pubs: CHRS Journal, Behind the Front Panel, Bay Area Radio, Hints and Kinks: 20 Years of CHRS free with membership. 13 events per year. Dues: \$30. www.californiahistoricalradio.com

CHRS/Central Valley Chapter. Monthly meetings, Eddie Enrique fantomradio@sbcglobal.net, www.cvantiqueradio.com.

CHRS/Sacramento Chapter (CHRS). Monthly meetings, Dale Tucker, chairman daletucker@surewest.net.

Carolinas Chapter/AWA (CC-AWA). Ron Lawrence, PO Box 3015, Matthews, NC 28106. Pub: Radio Daze, quarterly. Dues: \$10. Quarterly swap-meets. www.cc-awa.org.

Central Ohio Antique Radio Association (COARA). Contact Dave Poland (614) 890-5422 or Barry Gould (614) 442-1518. Quarterly meetings in March, June, September, and December and swap meets. Annual dues: \$12. Web Site: www.coara.org

Cincinnati Antique Radio Society (CARS). Meets the 2nd Wednesday of each month. Web site: www.cincinnati-antique-radio.org. E-mail: info@cincinnati-antique-radio.org. Contact: Bob Sands (513) 858-1755 E-mail: oltubes@roadrunner.com.

Colorado Radio Collectors (CRC). David Boyle, 1058 Colt Cir., Castle Rock, CO 80109. (303) 681-3258. Newsletter "The Flash", bimonthly starting in Jan. Dues: \$20. Annual Spring Show & Fall BBQ/Auction. www.radioace.com.

Delaware Valley Historic Radio Club (DVHRC). DVHRC PO Box 5053, New Britain, PA 18901. Pub: The Oscillator, monthly. Dues: \$20. Monthly meetings with swap meet in July. Sponsors twice-yearly Kutztown Radio Show (May and Sept). Web site: www.dvhrc.info.

Greater New York Vintage Wireless Association (GNYVWA). Jim Koehler 516-623-0035, Rich Lee 914-589-3751. Swap meet first Sunday of the month at Seaford, NY Long Island Rail Road Parking Lot. Web site: www.nyantiqueradio.org.

Heartland Antique Radio Association (HLARA). Gene Vickery, 7201 E. 64th St., Tulsa, OK 74133. E-mail: gene.vickery@hlara.org. Dues \$15. See Web site for more info. www.hlara.org.

Houston Vintage Radio Association (HVRA). PO Box 31276, Houston, TX 77231-1276. Membership info: Tom Burslem, tomburslem@yahoo.com. Pub: The Grid Leak, bi-monthly. Dues: \$20. Monthly meetings and auctions held 4th Saturday of each month. Web site: www.hvra.org.

Hudson Valley Antique Radio and Phonograph Society-AWA (HARPS). meets third Friday of the month at the Episcopal Church of Suffern, 65 Washington St., Suffern, NY 10901. Dues \$20. Info: <https://sites.google.com/site/ny-harps/>. Dale Cranston (845) 357-1615 dale.cranston@gmail.com

Indiana Historical Radio Society (IHRS). 245 N. Oakland Ave., Indianapolis, IN 46201-3360. Pub: IHRS Bulletin, quarterly. Dues: \$15 per year. Quarterly swap meets in various areas of the state. Web site: www.indianahistoricalradio.org.

Iowa Antique Radio Club and Historical Society (IARCHS). Dwight Baker, President. E-mail: vtaudio@hotmail.com. Pub: IARCHS Newsletter, quarterly. Dues: \$10. Annual Radiofest. www.iowa-antique-radio-club.com.

Jacksonville Antique Radio Society (JARS). Sean Olin (904) 386-8332, oldradios@bell-south.net. www.jarsradioclub.com.

Long Island Radio and TV Historical Society (LIRTVHS). 43 Sayville Blvd., Sayville, NY 11782. Membership \$25 per year. E-mail: liwhs@gmail.com. Web site: www.lirtvhs.org.

Michigan Antique Radio Club (MARC). Don Colbert, MARC, membership@michiganantiqueradio.org. Pub: The Michigan Antique Radio Chronicle, quarterly. Dues: \$20. Annual Extravaganza and other quarterly meets. www.michiganantiqueradio.org.

Mid-America Antique Radio Club (MAARC). Claude Chafin, 4223 E. 42nd St. Way, Independence, MO 64055. (816) 786-2313. Pub: The Broadcaster, quarterly. Dues: \$20. Semi-annual auctions and swap meets. <http://sites.google.com/site/midamericaantiqueradioclub/>

Mid-Atlantic Antique Radio Club (MAARC). Steve McAllister, 3903 Norwalk Place, Bowie, MD 20716. (816) 786-2313 E-mail: mcallister3903@comcast.net. Pub: Radio Age, monthly. Dues: \$20. Monthly meetings. www.maarc.org

Mid-South Antique Radio Collectors (MSARC). Terry Layman, 130 Saint Margaret Dr., Lexington, KY 40502. E-mail: layvinrad@twc.com. Meets last Saturday in April and October.

Military Radio Collectors Association (MRCA). Pete Hamersma, PO Box 467, Holderness, NH 03245. Web site: www.mrca.ar88.net.

Military Radio Collector's Group (MRCG). John Castorina, 675 Dana Dr., Santa Paula, CA 93060. E-mail: boatanchor@martasystems.com. Web site: www.mrcgwest.org

Museum of Broadcast Communications. 360 N. State St., Chicago, IL 60654. Dues: \$30. (312) 245-8200. Web site: www.museum.tv.

Museum of Radio & Technology. 1640 Florence Ave., Huntington, WV 25701. Web site: www.mrtwv.org.

Nashville Vintage Radio Club (NVRC). 514 E. Kings Rd., Smyrna, TN 37167. (615) 355-2005. Web site: www.musiccityvintage-radio.org.

National Capital Radio & Television Museum. Quarterly Publication: Dials & Channels. Membership dues: \$25 per year. Contact: www.ncrtv.org or 301-390-1020.

New England Antique Radio Club (NE-ARC). Info: (603) 772-7516. Bruce Phillips-President. Pub: Radio News, quarterly. Dues: \$12/year by mail, \$6/year by internet. Three swap meets a year in February, April, and September. Web site: www.nearc.net.

New Jersey Antique Radio Club (NJARC). Richard Lee - President (914) 589-3751; radio rich@prodigy.net. Membership: Marsha Simkin, 33 Lakeland Dr., Barnegat, NJ 08005. Meetings are 2nd Friday of the month from 7 to 10 pm alternating between Info Age, 2201 Marconi Rd., Wall Township, NJ 07719 and Bowen Hall, Princeton University. Monthly newsletter "The Jersey Broadcaster." Dues \$20. 3 swap meets and 4 repair clinics a year. December holiday party. Web site: www.njarc.org.

New Mexico Radio Collectors Club (NMRCC). Contact Ron Monty at ronmonty@comcast.net. Pub: New Mexico Radio Collectors Club Newsletter, monthly. Dues: \$20. Annual Sale & Show and monthly meetings. Web site: www.newmexicoradiocollectorsclub.com/.

Niagara Frontier Wireless Association (NFWA). Gary Parzy, 135 Autumnwood, Cheektowaga, NY 14227. Regional meets. Display at the Amherst Museum, Amherst, NY. Web site: www.nfwa.net.

Northland Antique Radio Club (NARC). PO Box 18362, Minneapolis, MN 55418. Pub: The NARC Newsletter, four/year. Dues: \$12. Four meets (including 2 swap meets) per year and Radio Daze event. www.northlandantiqueradioclub.com

Northwest Vintage Radio Society (NWVRS). Wendy Johnson-Kent, PO Box 82379, Portland, OR 97282-0379. (503) 891-4615, E-mail: wendy.johnson-kent@redcross.org. Pub: The Call Letter, monthly. Dues: \$25 a year. Monthly meetings. www.nwvrs.org.

Oklahoma Vintage Radio Collectors, OK City Chapter (OKVRC). Jim Collings, jrradio@cox.net, PO Box 50625, Midwest City, OK 73140-5625. Pub: OKVRC Broadcast News,

monthly. Dues: \$15 per year. Monthly meetings, spring and fall swap meets. For more information, visit <http://www.okvrc.org>.

Pittsburgh Antique Radio Society, Inc. (PARS). Chris Wells, 110 Fawn Valley Dr., McMurray, PA 15317. (724) 942-1113. Pub: The Pittsburgh Oscillator, quarterly. Dues: \$10. Eight meets a year including the April Tri State Radio Fest. www.pittantiqueradios.org.

Puget Sound Antique Radio Association (PSARA). PO Box 7567, Tacoma, WA 98417. Contact Linda Glaspey (425) 478-3643. Pub: The Horn of Plenty, monthly. Dues: \$25 per year. Meets 12 noon on the 3rd Sunday of each month (second Sunday in June & December) at the Cedar Valley Grange Hall, Lynwood, WA Annual swap meet in August. www.eskimo.com/~hhagen/psara

Radio Enthusiasts of Puget Sound (REPS). REPS Membership, 17334 Densmore Ave. N, Shoreline, WA 98133. Pub: Air Check, 9 times a year. Dues: \$20 per year. Monthly meetings, annual Radio Showcase. www.repsonline.org.

Society for the Preservation of Antique Radio Knowledge (SPARK). Dues: \$15. Annual Swap Meet, Monthly meeting, 7:30 pm Parkview Community Center, Kettering, OH. Contact: Dan Casey (513) 265-8466; E-mail: dansradioland@gmail.com. www.antiqueradios.com/spark.

Society of Wireless Pioneers (SOWP) - as of April 2, 2012 merged with the California Historical Radio Society (CHRS). www.californiahistoricalradio.com

Southeastern Antique Radio Society (SARS). Rich Rodgers, President, 113 Laurel Ridge Dr., Alpharetta, GA 30004. Pub: Newsletter, quarterly. Dues: \$16. Spring, Fall and Winter swap meets. Monthly dinner meetings, 2nd Monday of each month, in Norcross, GA. (678) 825-7998 www.sarsradio.com.

Southern California Antique Radio Society (SCARS). Jim Garrett, 15621 Fox Hills St., Westminster, CA 92683. (714) 891-1689. wa6ys@juno.com. Pub: SCARS Gazette, quarterly. Dues: \$20. Web site: www.antique radios.org.

Texas Antique Radio Club (TARC). Ed Engelen, 680 Lake Forest, Canyon Lake, TX 78133. Pub: Lone Star Waveform, monthly. Monthly meetings. Web site: www.tarc.gvtc webspace.net.

Tidewater Antique Radio and Phonograph Association (TARPA). Barry Callis, 3689 N. Landstown Rd., Virginia Beach, VA 23456. (757) 427-9667. E-mail: betty3689@aol.com. Meets last Tuesday of each month at the Mary Pretlow Library.

Vintage Radio & Communications Museum (VRCM). 115 Pierson Ln., Windsor, CT 06095. (860) 683-2903. Web site: www.vrcmct.org.

Vintage Radio & Phonograph Society (VRPS). PO Box 165345, Irving, TX 75016. Pub: The Soundwaves is published quarterly. Dues: \$20.00 annually. Monthly meetings, swap meets, Spring auction, annual convention. More information at Web site: www.vrps.org.

W. Va. Chapter, AWA (AWA-WVC). Geoff Bourne, 405 8th Ave., St. Albans, WV 25177. Newsletter, monthly. Dues: \$25.00 (includes museum membership). Quarterly meets, monthly meetings, classes.

Wisconsin Antique Radio Club, Inc. (WARCI). Greg Hunolt, (920) 893-0422, E-mail: ghunolt@excel.net. Check web site for swap meet dates. Annual dues: \$15. Web Site: www.warci.org

A Special Invitation to International Clubs...

A.R.C. wants to highlight your club and its events. Let our readers know what you're up to. Contact us today with your story.

Send an email to:
arc@antiqueradio.com

audioXpress

Advancing the Evolution of Audio Technology

From **wireless loudspeakers** to **wearable electronics**, **bass shakers** and **digital files** that are changing everything in today's pro audio industry...
Experience the vast evolution of technology with **audioXpress**.

SUBSCRIBE TODAY!

Call 800-269-6301
or order online at
www.audioXpress.com



audioXpress
111 Founders Plaza, Suite 300
East Hartford, CT 06108
USA P: 800-269-6301
Email: audioXpress@pcbpublink.com
www.audioXpress.com

ELECTRIC RADIO



Are you tired of plastic modern radios that you can't work on and are hard to understand? Are you looking for information on restoration of quality vintage receivers and transmitters? **Electric Radio** is the magazine for you! In print since May, 1989, we also have the largest vintage-only Ham classified section available.

Please send \$1 for a sample copy to:
ER, PO Box 242, Bailey CO, 80421
720-924-0171 email: 1editor2@indramag.com
WWW.ERMAG.COM



Join the **AWA** ANTIQUE WIRELESS ASSOCIATION

The original and largest
historical radio-collector group

- Publishes *AWA Journal* with
 - Battery and AC receiver restoration
 - Vacuum-tube history and collecting
 - Old-time amateur radio contests
 - Communications receivers
 - Free want-sell-swap ads
 - Early television
 - Horn loudspeakers
 - Reviews of current books
 - Keys and land-line telegraphy
 - News of U.S. and foreign clubs
 - Information on public radio museums
- Maintains unique radio-TV museum
- Produces the annual Rochester meet
- Co-sponsors local meets
- Publishes the annual *AWA Review*



Membership is only \$35 per year U.S.A.
(\$40 per year elsewhere) Write to:

AWA Membership Director
P.O. Box 421, Bloomfield, NY 14469-0421
www.antiquewireless.org

CQ Amateur Radio



CQ is devoted entirely to the things that Hams care about. It's a fine blend of technical ideas and projects, news and reviews of new Ham products and operating information, written and edited by a group of people who are absolutely crazy about this hobby!

SUBSCRIBE TODAY!

	USA	VE/XE	FN
1 yr	\$36.95	\$ 49.95	\$ 61.95
2 yrs	\$66.95	\$ 92.95	\$116.95
3 yrs	\$96.95	\$135.95	\$171.95

Monthly issues include:

- * Hamfest/Special Event Listings
 - * Hobby News
 - * New Product Info/Reviews
 - * Kit-Building & Projects
 - * CQ WW Contests Info/Results
- and much, much more!

CQ Amateur Radio

25 Newbridge Rd, Hicksville, NY 11801
Phone 516-681-2922

www.cq-amateur-radio.com

Philco knobs, pushbuttons, and escutcheons!





1941 models 41-250, 255, 256, 280, 285, 287, 290, 296, and 610

1942 models 42-355, 355T, 380, 380X, 390, and 390X

For 1940 models:
 Translucent wine red pushbuttons, set of eight \$16.

For 1941 models: Escutcheon \$29.95, Knobs, set of four \$20, Pushbuttons, set of eight \$16 opaque brown. **For 1942 models:** Escutcheon with gold trim as per original \$32.95. Knobs, set of four \$20, Pushbuttons, set of nine \$31.50.

Money order gets immediate shipment. Add \$5 s&h. California residents add 9.75% sales tax.

OLD TIME REPLICATIONS, 5744 Tobias Ave. Sherman Oaks, CA 91411. Phone 818-786-2500. Email oldtimerep@aol.com. www.antiqueradioknobs.com

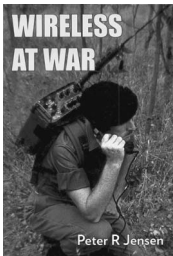
Got Something to Say?

Why not say it in the pages of *Antique Radio Classified*?

We love to hear from our readers. We may even want to publish your articles, club news, letters to the editor. Send your photos, too! Be a real part of *A.R.C.*

Contact us at arc@antiqueradio.com

Send us *your* story!



Wireless At War by Peter Jensen

Wireless at War presents a history of wireless technology and the advantages perceived for this technology's use in military armed conflicts. Soft cover, 352 pages.

\$29.95

Add \$3.50 shipping for the first book and \$1.00 for each additional book on USA orders. Contact us for non-USA shipping costs. NYS residents add sales tax.

A.R.C., PO Box 1558
 Port Washington, NY 11050
 Toll Free: (866) 371-0512
 Fax (516) 883-1077
 E-mail: ARC@antiqueradio.com
 Web: www.antiqueradio.com

A.G. Tannenbaum

Electronic Service Data

2043 Empire Central
 Dallas, Texas 75235
 Phone 214-654-0033

STILL THE



FOR

Service Data - 1920's - Present
 Newly Expanded Library

**Now selling tubes, equipment,
 test equipment and much more !**

Browse our expanded web offerings at
<http://www.agtannenbaum.com>

COLOSSAL VINTAGE ELECTRONICS AUCTION

Saturday June 14, 2014 • 10am



Truckloads of speakers, amps, radios, tubes, turntables, preamps, theater lights, guitar amps, records, and parts. Guitar parts from a 1960s-70s framus distributor. Guitar frets, necks, sheets of pick guard materials. Selections of bookshelf speakers and many huge concert and pa speakers. Peavey amps and preamps.

Rock and roll and other music posters. Several 1965 framus rolling stones posters.

NOS power tubes, not the new stuff but the old originals, including matched pairs. E134, 7591a, 7868, 7199 and many others by the score!!

Early 1950's - 1960's 45 records, many promos, dj records, one hit wonders, local labels. Rock and roll lp's. Old rek-o-kut transcription turntables. Edison phonographs, morning glory horns, and victrolas.

If anyone wants to consign items for this great event call Lee at 717-442-8529 or 302-438-1217.

Preview - thursday, june 12, 2014 12-4 pm, friday, june 13, 2014 10-4 pm and on the day of the sale from 8:30 am until 10 am.

Buyer's premium - 16% reduced to 12% for cash or good pa. Check. Out of state checks must be preapproved prior to the auction.

EMBASSY AUCTIONS INTERNATIONAL

5336 MINE RD., KINZERS, PA 17535
717-442-8529 or 302-438-1217
email embassyauctions@hotmail.com
web www.Auctionzip.Com id# 4741

PA AUCTION LICENSE AY001987

AUCTIONEERS: AMOS STOLTZFUS LIC AU0005077,

LEON KURTZ LIC AU000522L, GABY JARAMILLO LIC AU0005728

BOB'S ANTIQUE RADIOS & ELECTRONICS

SERVING THE VINTAGE RADIO COMMUNITY WITH QUALITY
AND LOW COST PRODUCTS FOR OVER 25 YEARS !!

<u>*CAPACITORS</u>		<u>*ELECTROLYTICS</u>	
<u>630 VOLT AXIAL</u>		<u>160 VOLT AXIAL</u>	
<u>VALUE</u>	<u>PRICE/25</u>	<u>VALUE</u>	<u>PRICE/25</u>
.001	\$6.00	10	\$13.00
.0022	6.15	22	16.00
.0033	6.20	33	21.00
.0047	6.25	47	24.00
.0068	6.35	100	30.00
.01	6.50	<u>450 VOLT AXIAL</u>	
.022	7.00	10	\$18.75
.047	7.50	22	28.00
.1	8.00	33	36.00
.22	15.00	47	45.00
.47	20.00	<u>10-PACK</u>	
1.	26.00	47	\$20.00
		100	28.00

FOR FURTHER INFO VISIT
RADIOANTIQUES.COM

\$1.75 FLAT RATE SHIPPING WITHIN THE USA

NO MINIMUM ORDER!

***STARTER KITS**
(CAPACITOR, MOST COMMON)

***TWO STAGE FILTERS**

***pilot lamps**

***NEON LAMPS**

***DIAL CORDS**

BOB'S ANTIQUE RADIOS AND ELECTRONICS

111 EAST 29TH STREET
LAGRANGE PARK, IL 60526
PHONE: 1-708-352-0648
FAX: 1-708-352-0647
radiobob1@radioantiques.com

A RARE OPPORTUNITY — RARE SETS FOR SALE FROM THE TERREY COLLECTION

Some things must go. Choices must be made.

2,000 Square Feet is not enough space for over 1000 radios!

Items for sale are duplicates or the result of fine-tuning the scope of the collection. And, please visit the collection — to just browse or for research. All sets are displayed on shelves and can be examined. Additionally, I have a collection of early books, catalogs, brochures, periodicals, and other ephemera, numbering in the thousands!



Conn. Tel. & Elect. Co. DR-6 Sodiion Receiver.
Receiver_with_(2)_D-11-1 Amplifiers



Mignon RLC5



Western Electric 4-C Receiver



RCA 106D (Factory Conversion from 106C)

Other items For Sale: Marconi of America Magnetic Detector; Western Electric 3-B Receiver, 4-D Receiver, 2-A Tuning Unit, 14-A Amplifier, 20-A Filter. Federal reproduction cabinets for Types 8, 9, 55 & 56.



Marconi of America Type CM-294A Receiver

OLD TECH - BOOKS & THINGS

For more information on the collection or on the items for sale: go to www.oldtech.com or contact: John Terrey, P.O. Box 803, Carlisle, MA 01741 – jvt@oldtech.com — Tele: (978) 369-9770



A.R.C., PO Box 1558, Port Washington, NY 11050

www.antiqueradio.com